

## **bellcode** Coded Access System

Including Systems;

CS109 - Combined door entry & coded entry

CK109 - Coded entry (216 keypad)

CK110 - Coded entry (217 Keypad)

CK200 - Coded entry (218 Keypad)

PD-078 Issue 1

## Summary of Features

- ! Up to 10 codes each of 1 - 8 Digits.
- ! Time restricted access.
- ! Duress Operation.
- ! Exit Facility.
- ! Lock Timer.
- ! Secure Programming via Keypad.
- ! Non-volatile Memory.

## Products

- 200 Coded access controller
- CK200 Complete kit incorporating 200 and 218 Keypad
- CK109 Complete kit incorporating 200 and 216 keypad
- CK110 Complete kit incorporating 200 and 217 keypad
- CS109 Combined coded access and door entry system

## Contents

General Description .....	5
Basic Operation .....	5
Main Features: .....	6
System Components .....	10
Model 200 Control Unit .....	10
Model 340 Power Supply .....	11
Electric Lock releases .....	11
2 Door Controller .....	11
Model 216 & 217 Keypad .....	12
Model 218 Keypad .....	13
Installation Instructions .....	14
Cable requirements .....	14
CK200 Wiring using the 218 keypad .....	15
CK109/CK110 Wiring (216 or 217 Keypads) .....	16
Fitting the Control Unit .....	17
Installing the Model 340 PSU .....	18
Installing the keypads .....	19
Electric Lock Release .....	21
Isolated lock relay contact .....	22
High current lock releases .....	23
Alarm Output .....	24
Time-clock .....	24
Exit Button .....	24

Programming the model 200 controller . . . . . 25

- General . . . . . 25
- Programming a New Access Code (Function 1 to 10) . . . . . 26
- Choosing an access code . . . . . 27
- Programming the Action Codes (Functions 51 to 60) . . . . . 28
- Changing the Security key (Function 91) . . . . . 30
- Enable / Disable the Lock reassurance tone (Function 92) . . . . . 31
- Setting the Lock Type (Function 93) . . . . . 32
- Programming a Code Entry Time Limit (Function 94) . . . . . 33
- Programming The Lock Duration (Function 95) . . . . . 34
- Programming a Lock Delay Time (Function 96) . . . . . 35
- Programming The Alarm Duration (Function 97) . . . . . 36
- Programming The Key Limit (Function 98) . . . . . 37
- Programming the Factory Settings from the Keypad (Function 99) . . . . . 38

Summary of Program Functions . . . . . 40

- Table 1 - Programming Access Codes . . . . . 40
- Table 2 - Programming of Other Functions . . . . . 41
- Table 3 - Programming of Action Codes . . . . . 42
- Table 4 - Summary of Action Numbers . . . . . 43

Testing and Troubleshooting . . . . . 44

- Programming the Factory Settings Using the Test Button . . . . . 46

Testing the model 200 controller . . . . . 47

- Testing The Lock Release Output . . . . . 47
- Testing the Alarm Outputs . . . . . 49
- Testing the Keypad . . . . . 50
- Keypad Matrix . . . . . 51
- Testing the controller with factory settings . . . . . 52
- Specification for the model 200 Controller . . . . . 53

**Combined Door Entry and Coded Access System . . . . . 55**

General Description . . . . . 56

- CS109 Complete Systems . . . . . 56
- Installation of the Door Entryphone System . . . . . 57

Cable Planning . . . . . 58

- Cable requirements . . . . . 59
- Installation Procedure . . . . . 60

Troubleshooting . . . . . 61

CS109 - 1 Wiring . . . . . 64

CS109 - N Wiring . . . . . 65

## General Description

The **bellcode** Coded Access system is a high quality, versatile security product, controlling access via a keypad and an electric lock release mechanism.

### Basic Operation

The model 200 Controller may be programmed with up to ten unique access codes. If a valid code is entered on the keypad, the lock release will operate for a preset duration.

The controller may be programmed to operate an audible alarm under various circumstances, for example, if an invalid code has been repeatedly entered; the alarm will operate for a preset period, during which time the lock release cannot operate.

The keypad has one green and one red LED to indicate the system status to the user; the green LED indicates that the lock release is operating, whilst the red LED indicates an invalid entry or an alarm condition. The green LED also flashes briefly when a key is pressed. The model 218 Keypad also has a built-in sounder with a brief tone when a key is pressed and a constant tone when the lock release is operating.

### Main Features:

#### Multi-coded

The controller has ten access codes available each of which can be 1 to 8 digits long. The extra codes are provided for a variety of possible uses:-

- Multi-user applications, e.g. for a small office block.
- Time-restricted access (described below).
- Duress access (described below).

#### Time-Restricted Access (Staff/Executive Operation)

Any of the ten access codes may be programmed to operate during a restricted time period, i.e. when an external time-clock switch is either open or closed.

For example, with factory settings, the operation of code 1 is unrestricted (Executive Code) whilst code 2 is restricted to when the time-clock input is closed (Staff Code).

Two codes could also be programmed to operate during alternate shifts. E.g. code 1 operates when the time-clock input is open and code 2 operates when the time-clock input is closed.

Refer to the section 'Programming the Action Codes' page 28 and Table 3 page 42 for further details.

### **Duress Access**

Any of the ten access codes may be set to duress mode. When a duress code is entered, the lock release will operate normally but immediately afterwards activate an alarm. The alarm device should be a discreet sounder or indicator designed to alert security staff.

Alternatively, the duress code can be programmed to directly operate the alarm, without releasing the door.

Refer to the section 'Programming the Action Codes' page 28 and Table 3 page 42 for further details.

### **Exit Facility**

The Exit facility allows the lock release to be operated directly from a push-button (for the preset time period). Typically this would be used to allow personnel to freely exit through the controlled door. The facility may also be used for a Fireman's keyswitch, or to interface with other security products such as a Door Entry Telephone System.

### **Lock Delay**

If required, the lock release can be programmed to operate after a preset time delay, following entry of the access code. This function is useful if the keypad is located a long way from the entrance.

### **Non-Volatile Memory**

The access codes and user programs are stored in a protected non-volatile EEPROM memory, which does not rely on batteries. The access codes and other programmable parameters are retained indefinitely without power.

### Programmable Options

In addition to the ten access codes the user may program the following other functions:

- ☛ Lock duration (1-99 seconds)
- ☛ Lock Type (Fail secure or fail safe)
- ☛ Enable/Disable the Lock reassurance tone (218 Keypad)
- ☛ Lock delay time (0-99 seconds)
- ☛ Alarm duration (1-99 seconds)
- ☛ Key entry limit (0-99 seconds)
- ☛ Code entry time limit (0-99 seconds)
- ☛ Time-restricted access mode
- ☛ Duress access mode.

## System Components

### Model 200 Control Unit

The Controller PCB is housed in a rugged ABS enclosure. Security can be further enhanced by placing the controller in a secured area. This arrangement provides a superior level of security when compared to the many combined keypad / controller units on the market, where access can usually be attained by vandalism of the keypad; with a correctly installed model **bellcode** system this is impossible.

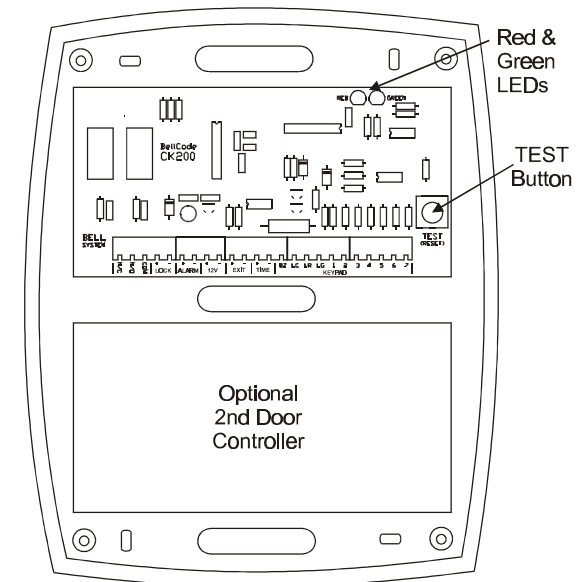

**Note** Access inside the unit is not required for programming.

## Model 340 Power Supply

The model 340 Regulated Power Supply is the standard unit recommended for use with the model 200 controller. Rated at 12V DC and 1Amp this power supply is sufficient to power a single controller, keypad and lock release (500mA max.), and a speech unit on combined systems (see combined systems, page 54).

## Electric Lock releases

The model 200 Controller has a 12V output, rated at 0.5A which can be configured for use with both Fail-secure (power to release the door) and Fail-safe (removing power to release the door) Lock Releases. This will drive a wide range of devices including magnetic locks.

A voltage free relay contact is also available rated at 1A, 30V AC/DC, for connecting to locks operating on a voltage other than 12V DC or for interfacing with an automated gate, etc. A Transient suppressor must be fitted across the lock if this voltage free output is used.

## 2 Door Controller

A 2<sup>nd</sup> Controller PCB (Part No. 201) can be added into the model 200 Control unit enclosure in conjunction with a second keypad and model 203 lock release to operate 2 doors independently.

## Model 216 & 217 Keypad

The Model 216 and 217 are 12-key Stainless-Steel Keypads, offering a high level of vandal resistance (suitable for indoor and sheltered outdoor locations). They are available with either an attractive alloy-cast surface-mounting enclosure or a flush-fitting (216 only) Zintec back-box. A red and a green LED indicator are provided for status indication; Green indicates door open; Red indicates alarm condition. The green LED also flashes when a key has been pressed.

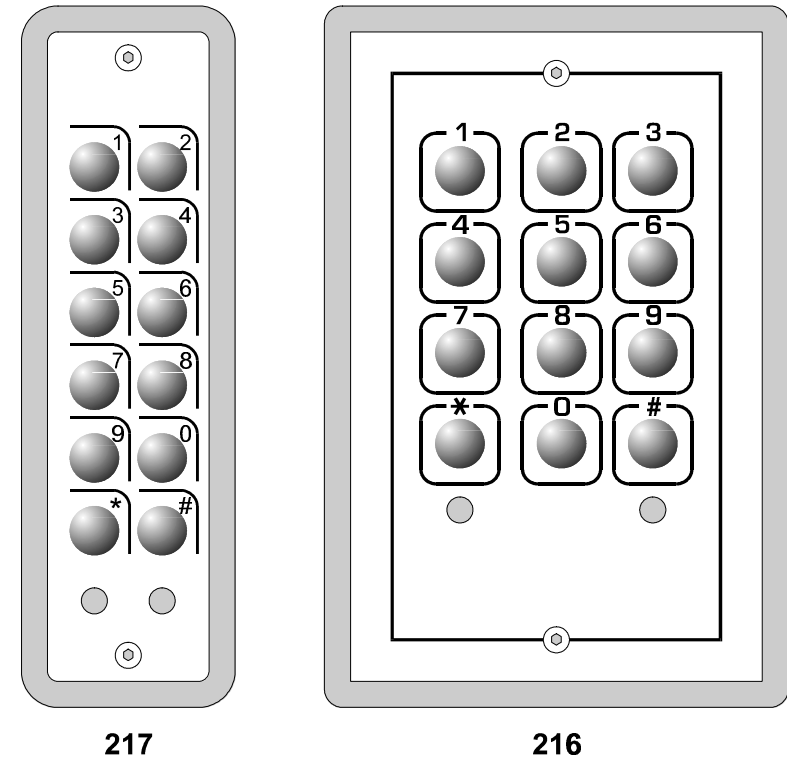

## Model 218 Keypad

The Model 218 is a 12-key touch sensitive keypad, fully sealed (IP68 rated) for all weather use. The keypad is machined from a single piece of Aluminium to create a perfectly smooth front face and a slimline body of only 19mm thick. A backplate is supplied to enable the keypad to be mounting to any vertical surface, such as a wall or post. A red and a green LED indicator are provided for status indication; Green indicates door open; Red indicates alarm condition. The green LED also flashes when a key has been pressed. A built-in sounder is used to reassure a key has been pressed, as well as indicate the door is unlocked.

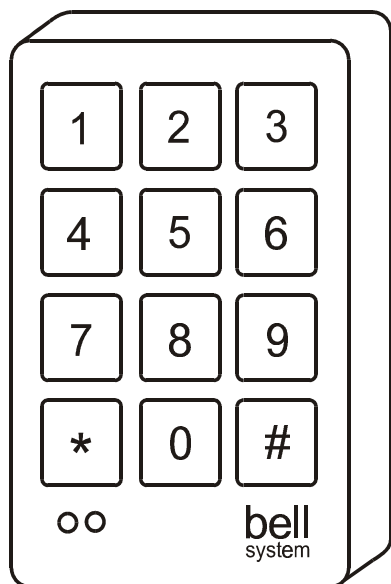

218

## Installation Instructions

Read carefully all of the information presented in this chapter and then install the system in accordance with the wiring diagram on page 15 or 16.

### Cable requirements

Unless otherwise specified below, it is recommended that the system be installed with solid-core telephone cable such as BT specification CW1308.

Connections	No. of cores	Cable length	Core diameter
340 Power Supply	2	2M max.	1.0mm
216/217 Keypad	10	300M max.	0.5mm
218 Keypad	11	300M max.	0.5mm
Lock release (up to 500mA)	2	up to 25M	0.5mm
		up to 100M	1.0mm
Alarm output (up to 50mA)	2	up to 100M	0.5mm
Time	4	100M max.	0.5mm
Exit	2	300M max.	0.5mm

In most cases cable length restrictions should not present a problem, however where longer lengths are required please refer to the manufacturer for advice.



### CK200 Wiring using the 218 keypad

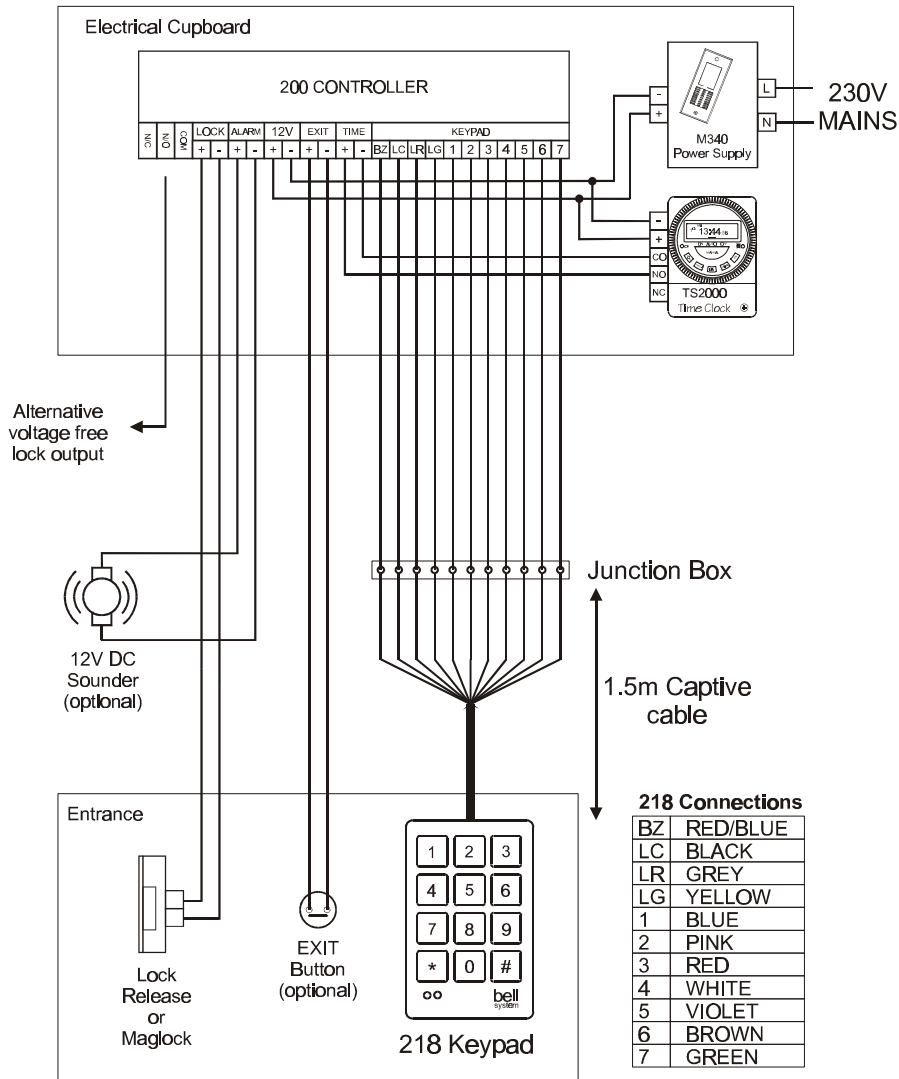

### CK109/CK110 Wiring (216 or 217 Keypads)

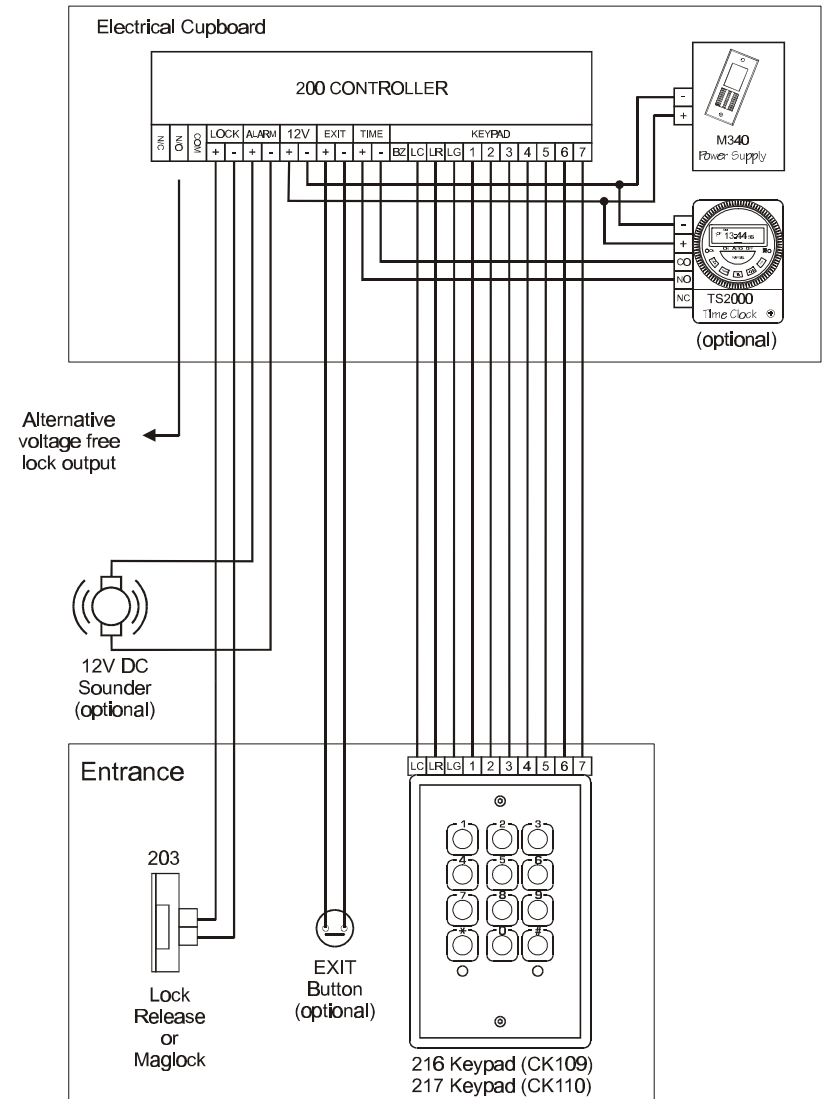

## Fitting the Control Unit

The model 200 controller is supplied in an ABS enclosure which should be installed in a protected indoor environment. The box contains a number of mounting holes, cable knock-outs. For safety reasons do not modify the box in any way.

## Installing the Model 340 PSU

The model 340 Power Supply must be placed in a protected indoor environment, close to a 240V electrical supply, e.g. an electrical cupboard. Connections to the 240V AC mains supply must be carried out by a qualified electrician or similar competent person, and made in accordance with accepted safety practices.

A two-pole switch (as provided by a Consumer Unit or Switch-Fuse) must be included to isolate both Live and Neutral during Installation or Maintenance, and have a contact isolation of 3mm minimum. The circuit must be protected by a current limiting fuse or other device with a maximum rating of 5A.

The model 340 power supply is protected by a mains fuse; always replace this with the correct type and rating:

T200mA 250V (20mm glass fuse, 200mA, 250V, Time delay, approved to BSEN60127 or equivalent.)

Use only mains cable to BS6004, BS6500, or equivalent, within the following specified limits:

	Minimum	Maximum
Conductor Diameter	1.0mm (0.75mm <sup>2</sup> )	2.25mm (4mm <sup>2</sup> )
Cable Diameter	4.0mm	8.0mm

## Installing the keypads

Do not run the cable alongside mains cables or other transmission cables for any great distance. The keypad interface has a high degree of noise immunity, which is adequate in most situations. With very long cable runs, especially if operating in a noisy environment, it is advisable to use a screened cable; connect the screen to DC negative (12V -) at the Controller.

### 216/217 Keypad

The keypad is supplied with an Allen key for removing the security screws in the front panel and gaining access to the terminals. When fixing the keypad ensure any drainage holes are at the base of the keypad and clear.

Both keypads require 10 connections to the controller as shown in the wiring diagram on page 16.

### 218 Keypad

The keypad is supplied with a security Hex bit (replacement Part No. 62F) to remove the security screw holding the keypad to the back mounting plate. Once removed the keypad can be unhinged and pushed up to detach.

Mounting holes are provided in the back plate to fix to a vertical wall.

The Keypad requires 11 connections to the controller as shown in the wiring diagram on page 15. A 1.5m integral captive cable is already provided.

## Electric Lock Release

The model 200 Controller PCB has a single pair of connections for connecting either a Fail-safe or Fail-secure electric lock release. The controller is setup with a Fail-secure output as standard. If a Fail-safe type output is required please refer to 'Setting the Lock Type (Function 93) on page 32.

**FAIL SECURE** : These devices require power to release the lock and will secure the door in the event of power failure. These are the most commonly used lock releases.

**FAIL SAFE** : Use these connections for 'Fail-Safe' lock releases and magnetic locks. Both of these devices require continuous power to lock the door and will release the door if power fails.

The output is rated at 12V DC with a maximum current consumption of 0.5A. For lock releases of higher current specification please refer to the section titled 'High current lock releases'.

An isolated relay contact is also available for non-standard lock releases, please refer to the next section.

## Isolated lock relay contact

An isolated relay contact has been provided to interface with non-standard locks and other devices. The load must not be rated above 1A 30VAC/DC.

Inductive loads must have a transient suppression device, this is normally connected directly across the load.

Alternatively the contact can be used to trigger or interface with other equipment; for example, to switch on a surveillance camera, trigger a car-park gate, or give an audible indication.

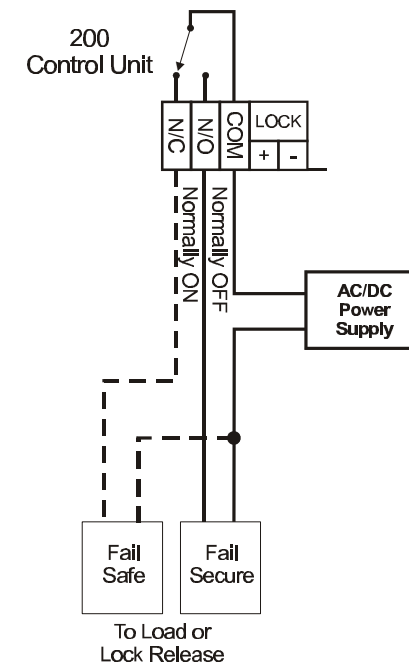

## High current lock releases

For a lock release or a magnetic lock rated higher than 0.5A or for AC operation an additional power supply will be required. In addition a relay must be used if the lock is rated above 1A to interface with the controller.

The relay contacts, or the lock-release, must be fitted with a suitable suppression device to prevent electromagnetic interference being generated by the coil of the lock release. (Refer to the manufacturer for further advice).

Consideration should be given to the problem of a voltage drop at the lock release. Refer to the manufacturer of the particular lock release for information on suitable cable length/thickness and power supply rating.

## High Current Lock Release

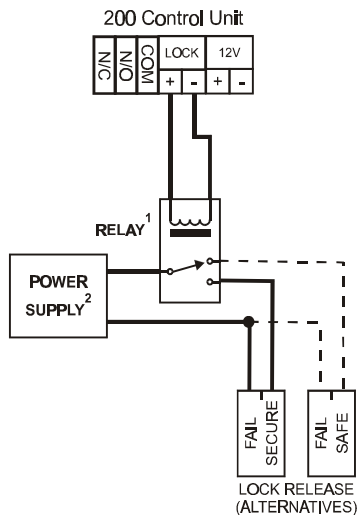

**Notes:**

1. Single-pole changeover relay, contact rating as per lock release. Lock release or contact must be suppressed for EMI.
2. Power Supply Is AC or DC and rated according to lock release requirements. (polarity is not usually important)

**Suitable Bell System Products**

Product	Description	Fall Safe	Fall Secure
89	12V DC Relay, 10A Contact.		
340	12V DC Power Supply,		1A
440	12V DC Power Supply,	1.5A	2A
225	12V AC Power Supply. This power supply incorporates a relay, eliminating the need for an external relay: 200 'COM' to 225 'Z' and 200 'N/O' to 225 'H' instead.		2A

## Alarm Output

The output is 12V DC at 50mA and may drive a variety of DC sounders, indicators, or a relay for more powerful devices.

## Time-clock

The terminal pair marked 'TIME' on the Controller PCB can be connected to an external switch to enable the second access code (as factory set). This switch may be a simple keyswitch, operated manually, or more usually a Time-Clock. The switch contact must be fully isolated (i.e. voltage-free).

## Exit Button

The terminal marked 'EXIT' may be connected to an external push-button for egress operation. Momentarily operating this button will directly operate the lock release for the programmed duration.

Alternatively, the input may be used with a Fireman's Override keyswitch, which should be of the normally-open type. If this feature is to be used it is important that the lock release be of a continuously-rated design.

In general, a switch connected to the 'EXIT' terminals should be fully isolated i.e. voltage-free.

## Programming the model 200 controller

### General

The 10 access codes, lock time etc, are all programmed via the keypad. To prevent unauthorised use, a security key (1 - 8 digits) must be entered.

The basic principle of programming is as follows:

#### Procedure

- ☞ Enter the security key (1 to 8 digit number).
- ☞ Enter a key sequence on the keypad.
- ☞ Observe both the red and green LEDs flash for one second.
- ☞ When all functions are programmed, exit program mode by pressing **\*\***.

Each program function is described in detail on the following pages.

## Programming a New Access Code (Function 1 to 10)

The controller has ten access codes. Each code may be between 1 and 8 digits long.

#### Procedure

- ☞ Enter the security key.
- ☞ Type : **<1 - 10> \* <New Code> #**
- ☞ Red and green LEDs Flash
- ☞ Exit program mode by pressing **\*\***

#### Examples

**1 \* 7754#**

(code 1 = 7754)

**5 \* 8652#**

(code 5 = 8652)

## Choosing an access code

To ensure an adequate level of security it is recommended that a minimum of 4 digits be used for each access code, giving 10,000 combinations. Codes should be chosen carefully to avoid obvious sequences and repetitions (e.g. 12345, 258, 4444) which may be easily guessed or discovered. Try to choose codes with a random appearance (e.g. 6149, 186403) and avoid telephone numbers and other meaningful codes which, again, may be guessed by a would-be intruder. It is also a good idea to regularly change the access codes.

When choosing access codes it is important that no code is a subset of another code, e.g. If code 1 = 234 and the code 2 = 12345, code 2 would never open the door as 234 is a subset of 12345.

## Maintenance

It is important also that the keypad be regularly cleaned to remove finger marks which would otherwise give clues as to the keys used in the access code.

## Programming the Action Codes (Functions 51 to 60)

Each access code has an associated action number. This is a single digit from 0-9 which determines the action that occurs following the entry of that access code.

**Procedure**

- ☞ Enter the security key.
- ☞ Type : <51 - 60> \* <Action No> #
- ☞ Red and green LEDs Flash
- ☞ Exit program mode by pressing \*\*

Example

**51 \* 1 #**

Code 1:Act No=1  
(Operate lock  
always)

No	Function	Key Sequence	Factory Setting
51	Code 1 Action Number	51 * <0-9> #	1 (Operate always)
52	Code 2 Action Number	52 * <0-9> #	2 (Operate when Time closed)
53 - 60	Codes 3 to 10 Action Number	53 - 60 * <0-9> #	0 (Disabled)

Action No.	Description
0	No action ( code is disabled)
1	Lock operates
2	Lock operates only if Time contacts are closed
3	Lock operates only if Time contacts are open
4	Lock operates followed by alarm (duress code)
5	Lock, followed by alarm (duress code), if the Time contacts are closed
6	Lock, followed by alarm (duress code), if the Time contacts are open
7	Alarm operates
8	Alarm operates only if Time contacts are closed
9	Alarm operates only if Time contacts are open

## Changing the Security key (Function 91)

The security key is the code that must be entered on the keypad to gain access to program mode, this is NOT the code to get in the building.

To ensure an adequate level of security it is recommended that a minimum of 4 digits be used for the security key, giving 10,000 combinations.

### Procedure

- ☛ Enter the current security key.
- ☛ Type : **91 \* <New Key> #**
- ☛ Red and green LEDs Flash
- ☛ Exit program mode by pressing **\*\***

Example  
**91 \* 87305 #**  
 (security key = 87305)

Factory Setting = 1212



## Enable / Disable the Lock reassurance tone (Function 92)

This only applies to systems fitted with the 218 Keypad.

In normal operation the sounder in the 218 keypad will make a continuous tone while the lock is operating (including when the lock operates from using an EXIT button or Fireman's keyswitch). In some situations this may become a nuisance, especially if the lock operates for a very long time. The sounder can be turned on or off by following the procedure below.

Note the keypad reassurance beeps will still be heard. If no sound at all is required, disconnect the keypad wire going into terminal 'BZ' on the controller.

### Procedure

- Enter the security key.
- Type : **92 \* <0/1> #**
- Red and green LEDs Flash
- Exit program mode by pressing **\*\***

Example

**92 \* 0 #**

(Disabled)

**92 \* 1 #**

(Enabled)

Factory Setting = 1 (Enabled)

## Setting the Lock Type (Function 93)

This setting tells the controller whether a Fail safe (including Maglocks) or Fail secure lock is connected. Follow the procedure below to change the setting.

### Procedure

- Enter the security key.
- Type : **93 \* <0/1> #**
- Red and green LEDs Flash
- Exit program mode by pressing **\*\***

Example

**93 \* 0 #**

(Fail secure)

**93 \* 1 #**

(Fail safe)

Factory Setting = 0 (Fail secure)

## Programming a Code Entry Time Limit (Function 94)

This limits the time allowed for entry of the correct access code. Timing starts from pressing the first key and if the remainder of the access code has not been entered before this time limit elapses the alarm is activated. The code entry time limit is programmable from 1-99 seconds or this feature is disabled by selecting a time of '0'

### Procedure

- ☞ Enter the security key.
- ☞ Type : **94 \* <0-99> #**
- ☞ Red and green LEDs Flash
- ☞ Exit program mode by pressing **\*\***

Example  
**94 \* 20 #**  
(limit of 20 secs)

Factory Setting = 0 (disabled)

**NOTE:** When the code entry time limit function is disabled the controller will automatically engage a timed memory clear function. If no key has been pressed for 10 seconds all previous entries will be cleared; this is important to ensure that the system cannot be left primed by a partially entered but otherwise correct access code.

## Programming The Lock Duration (Function 95)

This is the duration the lock release will operate for when triggered by an access code or by the 'EXIT' input. It is programmable in the range 1-99 seconds.

### Procedure

- ☞ Enter the security key.
- ☞ Type : **95 \* <1-99> #**
- ☞ Red and green LEDs Flash
- ☞ Exit program mode by pressing **\*\***

Example  
**95 \* 7 #**  
(7 seconds)  
**95 \* 12 #**  
(12 seconds)

Factory Setting = 3 seconds

## Programming a Lock Delay Time (Function 96)

This function causes a delay (0-99 seconds) to be introduced between the triggering of the lock release and its operation. Typically, this facility is used when the keypad is located some distance from the entrance.

### Procedure

- ☞ Enter the security key.
- ☞ Type : **96 \* <0-99> #**
- ☞ Red and green LEDs Flash
- ☞ Exit program mode by pressing **\*\***

Example

**96 \* 3 #**

(3 second  
delay)

Factory Setting = 0 seconds

## Programming The Alarm Duration (Function 97)

The alarm output is triggered by either a duress code or by a repeated entry of an incorrect code. The Alarm duration determines the time for which this output is active before automatically resetting. It is programmable in the range 1-99 seconds.

### Procedure

- ☞ Enter the security key.
- ☞ Type : **97 \* <1-99> #**
- ☞ Red and green LEDs Flash
- ☞ Exit program mode by pressing **\*\***

Example

**#97 \* 60 #**

(60 seconds)

Factory Setting = 30 seconds

## Programming The Key Limit (Function 98)

The key limit determines the number of keys that may be pressed in attempting to enter the correct access code before activating the Alarm. Choose a value which is a multiple of the number of digits in the code e.g for a 4 digit code set the key limit to 12 to allow 3 attempts. To disable this feature program the key limit to 0.

### Procedure

- Enter the security key.
- Type : **98 \* <0-99> #**
- Red and green LEDs Flash
- Exit program mode by pressing **\*\***

Example  
**98 \* 12 #**  
(limit 12 keys)

Factory Setting = 0 (disabled)

## Programming the Factory Settings from the Keypad (Function 99)

In the event of any problems, always return to Factory settings.

### Procedure

- Enter the security key.
- Type : **99 \* #**
- Red and green LEDs Flash
- Exit program mode by pressing **\*\***

If you have forgotten the security key see 'Programming the Factory Defaults Using the Test Button' page 46.

## Summary of Factory Settings

No	Function	Factory Setting
1	Program Code 1	1 2 3 4 5
2	Program Code 2	6 7 8 9 0
3 - 10	Program Codes 3 to 10	Disabled
51	Code 1 Action Number	1 (Operate always)
52	Code 2 Action Number	2 (Operate when Time closed)
53 - 60	Code 3 to 10 Action Numbers	0 (Disabled)
91	Security key	1 2 12
92	Lock Reassurance tone	1 (Enabled)
93	Lock Type	0 (Fail secure)
94	Code Entry Time Limit	0 (Disabled)
95	Lock Duration	3 seconds
96	Lock Delay	0 (Disabled)
97	Alarm Duration	30 seconds
98	Key Limit	0 (Disabled)

## Summary of Program Functions

Table 1 - Programming Access Codes

No.	Function	Key sequence	Factory Setting
1	Program Code 1	1 * <1-8 digits> #	1 2 3 4 5
2	Program Code 2	2 * <1-8 digits> #	6 7 8 9 0
3	Program Code 3	3 * <1-8 digits> #	Disabled
4	Program Code 4	4 * <1-8 digits> #	Disabled
5	Program Code 5	5 * <1-8 digits> #	Disabled
6	Program Code 6	6 * <1-8 digits> #	Disabled
7	Program Code 7	7 * <1-8 digits> #	Disabled
8	Program Code 8	8 * <1-8 digits> #	Disabled
9	Program Code 9	9 * <1-8 digits> #	Disabled
10	Program Code 10	10 * <1-8 digits> #	Disabled

**Table 2 - Programming of Other Functions**

No	Function	Key Sequence	Factory Setting
91	Security key	91 * <1-8 digits> #	1 2 12
92	Lock Reassurance tone	92 * <0/1> #	1 (Enabled)
93	Lock Type	93 * <0/1> #	0 (Fail safe)
94	Code Entry Time Limit	94 * <0-99 secs> #	0 (Disabled)
95	Lock Duration	95 * <1-99 secs> #	3 seconds
96	Lock Delay	96 * <0-99 secs> #	0 (Disabled)
97	Alarm Duration	97 * <0-99 secs> #	30 seconds
98	Key Limit	98 * <0-99 keys> #	0 (Disabled)
99	Program Factory Settings	99 * #	

**Table 3 - Programming of Action Codes**

No	Function	Key Sequence	Factory Setting
51	Code 1 Action Number	51 * <0-9> #	1 (Operate always)
52	Code 2 Action Number	52 * <0-9> #	2 (Operate when Time closed)
53	Code 3 Action Number	53 * <0-9> #	0 (Disabled)
54	Code 4 Action Number	54 * <0-9> #	0 (Disabled)
55	Code 5 Action Number	55 * <0-9> #	0 (Disabled)
56	Code 6 Action Number	56 * <0-9> #	0 (Disabled)
57	Code 7 Action Number	57 * <0-9> #	0 (Disabled)
58	Code 8 Action Number	58 * <0-9> #	0 (Disabled)
59	Code 9 Action Number	59 * <0-9> #	0 (Disabled)
60	Code 10 Action Number	60 * <0-9> #	0 (Disabled)

**Table 4 - Summary of Action Numbers**

Code	Action
0	No action ( code is disabled)
1	Lock operates
2	Lock operates only if Time contacts are closed
3	Lock operates only if Time contacts are open
4	Lock operates followed by alarm (duress code)
5	Lock, followed by alarm (duress code), if the Time contacts are closed
6	Lock, followed by alarm (duress code), if the Time contacts are open
7	Alarm operates
8	Alarm operates only if Time contacts are closed
9	Alarm operates only if Time contacts are open

**Testing and Troubleshooting**

Use the table below to determine the most probable cause of a fault condition and perform any suggested tests which are described in detail in the following pages.

Symptom	Possible Cause/Remedy
When power applied nothing happens (LEDs do not flash)	<ul style="list-style-type: none"> <li>● Power Supply is overloaded; Remove external connected components until the fault disappears (12V+/-, Lock(s), Alarm, Keypad)</li> <li>● Check Power Supply Fuses. Always replace with fuses of the correct type and rating.</li> </ul>
Red and Green LEDs flash together when attempting to operate lock-release	<ul style="list-style-type: none"> <li>● The LOCK release output is short-circuited or the release is of an incorrect rating; Check lock-release output (page 47)</li> </ul>
Lock release does not operate when Exit Button is operated.	<ul style="list-style-type: none"> <li>● Test by applying a short-circuit directly to the 'EXIT' terminals; Check connections to Exit button.</li> </ul>

Symptom	Possible Cause/Remedy
Lock operates when the test button is used but does not operate when code is entered.	<ul style="list-style-type: none"> <li>● Check Controller is correctly programmed; Restore to Factory Settings (page 38, 46);</li> <li>● Test keypad and connections (page 50)</li> </ul>
Lock release is permanently active	<ul style="list-style-type: none"> <li>● 'EXIT' terminals are short-circuited;</li> <li>● Temporarily remove connections to 'EXIT' and re-test unit.</li> </ul>
Lock release operates in reverse	<ul style="list-style-type: none"> <li>● The Lock Type function 93 is incorrectly set; Refer to page 32.</li> </ul>
Alarm output does not operate	<ul style="list-style-type: none"> <li>● Ensure unit is correctly programmed pages 38, 46)</li> <li>● Test Alarm output (page 49)</li> </ul>
Security key doesn't work	<ul style="list-style-type: none"> <li>● Restore factory settings (page 46) and reprogram as required.</li> </ul>

## Programming the Factory Settings Using the Test Button

In the event of any problems, always return to Factory settings. If the keypad is not working, or the security key has been forgotten, the test button inside the Controller can be used to restore factory settings.

This operation will restore all codes, times and functions to the factory settings (see the table on page 39 for the complete list).

This facility is useful for fault diagnosis. It makes use of the Test Button on the PCB rather than the keypad (which may have been incorrectly installed). It is always advisable to return to this condition whenever the unit appears to malfunction during installation or following an unsuccessful programming session.

### To program Factory Settings:

- ☞ Press and hold the TEST button.
- ☞ Observe the red and green LEDs on (5 seconds).
- ☞ Observe the red and green LEDs alternating (3 seconds).
- ☞ Finally the red and green LED will flash for 1 second and extinguish. The Factory setting are now programmed; release the TEST button.



## Testing the model 200 controller

### Testing The Lock Release Output

It is advisable to disconnect any connections to the ALARM output temporarily for this test. This test uses the TEST button inside the controller enclosure.

- **Press and hold the PCB TEST button:**

Both of the Lock Output and the Alarm Output will operate; both red and green LEDs will illuminate.

Warning, after 5 seconds the LEDs will start to alternate and the lock and alarm outputs will stop operating; you should release the test button at this stage to avoid programming the factory settings.

- **If the LEDs turn on as described but the lock release fails to operate:**

Check the lock release and its wiring by moving the lock connections to 12V+/- . The Controller PCB can be checked by measuring the voltage output on the lock release pair; this should be the same as the power supply (13.8V). Note: If the Lock type has been set to fail-safe the output will have voltage present **except** when the TEST button is pressed.

- **If pressing the TEST button causes the LEDs to flash immediately:**

The power supply has been overloaded; look for either a short-circuit across the lock release output, or check that the lock release used requires less than 500mA @12V.

## Testing the Alarm Outputs

Check that the alarm output is correctly wired to the device being used. It is advisable to temporarily disconnect the lock release if it has not already been tested.

- **Press and hold the PCB TEST button:**

Both the Lock Output and the Alarm Output will operate, and both red and green LEDs will illuminate.

After 5 seconds the LEDs will start to alternate and the lock and alarm outputs will stop operating; you should release the test button at this stage to avoid programming the factory settings.

- **If the LEDs turn on as described but the alarm output fails to operate:**

Check the alarm device and its wiring by moving the connections to 12V +/- . The Controller PCB can be checked by measuring the voltage output on the alarm output pair; this should be the same as the power supply (13.8V).

- **If pressing the TEST button causes the LEDs to flash immediately:**

The power supply has been overloaded; look for either a short-circuit across the Alarm output, or check that the alarm device used requires less than 50mA @12V.

## Testing the Keypad

This test makes use of the red and green LED provided on the model 216/217/218 keypads. If another keypad is being used which does not have LEDs it is possible to use the LEDs on the PCB which duplicate their function; In this case, it may be necessary to temporarily relocate the keypad closer to the controller using a short length of cable. Obviously, if the system only exhibits a fault when the keypad is returned to its position then the keypad cabling must be the cause. Note pressing the keys in any sequence will produce a short green LED flash.

- ☞ Program the unit to Factory Settings (see page 38, 46).

- ☞ Press the keys in the following sequence **\* 9 8 7 6 5 4 3 2 1 0**

- ☞ If the controller reads these keys in the same sequence then the green LED will give a long flash for each key-stroke. On 218 Keypads you will also get a long beep.

- ☞ If any keys appears out of sequence then the red LED will flash brief. This ends the test sequence (until the sequence is restarted with the \* key).

- ☞ To find more incorrect keys repeat the sequence, replacing the keys found to be incorrect with the # key (This only works if the # key is correct!).

- ☞ A Faulty Row or Column of keys (or more) will tend to indicate a connection fault (use the key matrix to identify faulty connection), whereas a single faulty key would tend to suggest a faulty keypad.

## Keypad Matrix

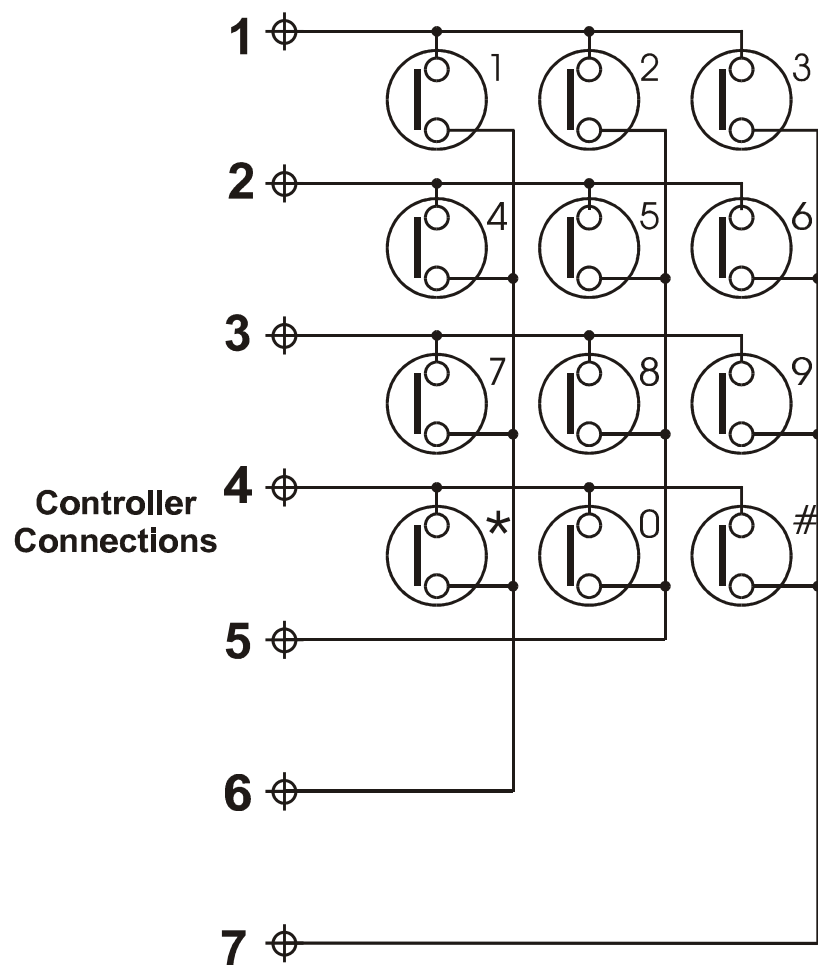

## Testing the controller with factory settings

Before proceeding with this test ensure that the lock release and alarm device (if used) are working correctly by following the tests on pages 47 and 49

Program to factory settings by following the instructions on page 38, 46.

- ☛ Type in code 1 (**1 2 3 4 5**) - this should operate the lock release for 3 seconds.
- ☛ Remove connections to the 'TIME' terminals and type code 2 (**6 7 8 9 0**), nothing should happen. Now short-circuit the 'TIME' terminals together with a short piece of wire and retype code 2 (**6 7 8 9 0**) - the lock release should operate for 3 seconds.
- ☛ Reprogram code 1 to another value by following the instructions under the heading 'Programming a new access code' (page 25); check that the new code operates the lock release and that the old one does not.

If any of the above tests should fail then follow the keypad test procedure.

## Specification for the model 200 Controller

### Lock

Output Voltage: 13.8V (nominal)

Load (maximum): 0.5A (load inductive or resistive)

### Alarm

Output Voltage: 13.8V (nominal)

Load (maximum): 50mA

### Dimensions

PCB Only: 152mm x 76mm

ABS Enclosure: 230mm x 185mm x 45mm

### Standards



This Product complies with European Directive 89/336/EEC on ElectroMagnetic Compatibility and Low Voltage Directive 73/23/EEC.

**Made in the United Kingdom**

## General Description

The CS109 series systems are combined Door Entry Telephone and Coded Access Systems. The entrance panel incorporates a push button for each telephone, a speaker grill and an integral keypad, similar in style to the Model 216 keypad.

### CS109 Series

### Combined Door Entry and Coded Access

### System

**Bell System (Telephones) Ltd.**

### CS109 Complete Systems

The CS109-N systems include all of the components necessary for a single-door Coded Access and Door Entry Telephone System:-

- 1 Model 200 Coded Access Controller.
- 1 CP109-*N* Anodised Aluminium Entrance Panel with integral keypad and surface mounting back-box.
- 1 61 or 51 Speech unit.
- N* Model 801 Door Entry Telephones
- 1 Model 203 Lock Release.

*N* - specifies the number of push-buttons/telephones (eg CS109-3: 3 phone system)

## Installation of the Door Entryphone System

From an electrical point of view, the combined systems may be regarded as separate door entry and coded access systems with the exception of a common lock release. The coded access system and its installation is described in detail in the preceding half of this manual. The wiring diagram on page 64 shows the wiring connections for the Door Entry Telephone System, including the simple connections which interface with the model 200 Coded Access Controller.

### The Model 801 Door Entry Telephone

This is designed to be wall mounted in a convenient indoor location.

### The Entrance Panel

The entrance panel, containing the speech unit, is supplied with either a surface or flush-mounting back box. It should be mounted on a wall near the front door, and in a sheltered location.

### Extension Phones

Each apartment can have up to 3 extension phones (4 phones in total).

### Tradesman button (optional)

This is used in conjunction with a time-clock (such as the TS2000) to allow tradesmen access during restricted hours. The time-clock may be 240V AC or 12V DC operated, but must have a voltage-free isolated contact.

## Cable Planning

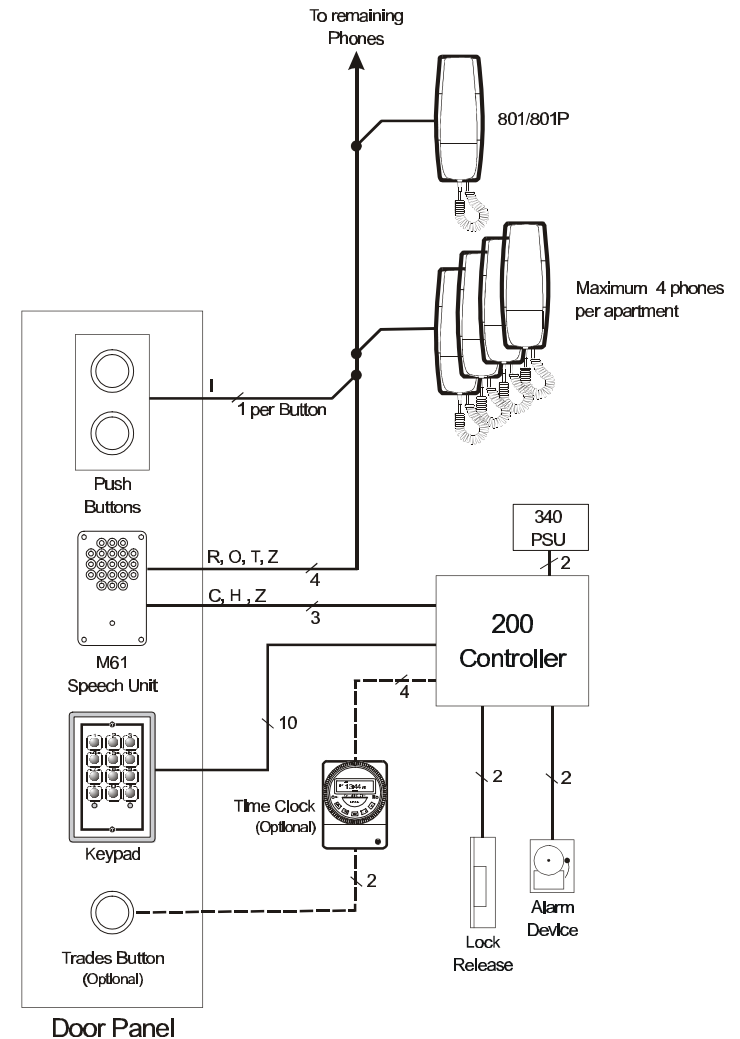

## Cable requirements

For optimum clarity of speech it is strongly recommended that this system is installed using twisted-pair telephone cable (e.g. type CW1308). Use one of the pairs for the R & O connection between the speech unit and the telephone.

Connections	No. of cores	Core diameter	Cable length
340 PSU	2	1.0mm	3M max.
Phone	4 + 1 per phone	0.5mm	100M max.
Speech Unit and Keypad	13	0.5mm	100M max.
Lock release (up to 500mA)	2	0.5mm	up to 25M
		1.0mm	up to 100M
Alarm output (up to 50mA)	2	0.5mm	up to 100M
Time clock	4	0.5mm	100M max.
Exit	2	0.5mm	100M max.
Trades Button	2	0.5mm	100M max.

In most cases cable length restrictions should not present a problem, however where longer lengths are required please refer to the manufacturer for advice.

## Installation Procedure

Connect all items by following the wiring diagram, on page 64 or 65. It is strongly recommended that a single telephone be connected at a time and fully tested before proceeding to the next.

### Speech adjustment

The model 61 speech unit have two pots at the rear for adjustment of speech levels as follows:

Volume A (Speaker symbol): Speech level at the Entrance Panel

Volume B (Mic Symbol): Speech level at the Telephone

## Troubleshooting

Use the table below to determine the most probable cause of a fault condition. Refer also to page 44 for problems with the coded access system.

### Telephone Problems

Symptom	Possible Cause/Remedy
Low Speech Volume	<ul style="list-style-type: none"> <li>● Volume adjustment required on speech unit.</li> <li>● Speech unit is not tight against the panel grill.</li> <li>● Panel grill is blocked</li> <li>● More than one telephone is off the hook.</li> <li>● Speech unit supply voltage is low. Check 10V - 15V across 'C' and 'H'.</li> </ul>

Symptom	Possible Cause/Remedy
Constant tone/feedback when in use.	<ul style="list-style-type: none"> <li>● Volume adjustment required on the Speech Unit.</li> <li>● Speech Unit is not tight against the panel grill.</li> <li>● 'O' connection between Speech unit and telephone is open circuit.</li> <li>● Entrance panel and telephone are too close together.</li> <li>● The entrance panel is surrounded by reflecting walls.</li> <li>● Panel grill is blocked.</li> </ul>
No speech when the phone is buzzed	<ul style="list-style-type: none"> <li>● Wiring fault on the speech signal connections 'R' or 'T': 'R' carries the phone microphone signal to the speech unit; 'T' carries the Speech unit microphone to the phone.</li> </ul>



Miscellaneous Problems

Symptom	Possible Cause/Remedy
Telephone will not buzz.	<ul style="list-style-type: none"> <li>Faulty 'O' or 'I' line between power supply and phone. Check 10.5V - 15V across 'I' and 'O' when called.</li> </ul>
Telephone 'DOOR' button does not operate release; Controller test button does operate the lock	<ul style="list-style-type: none"> <li>Missing connection to Controller EXIT terminal.</li> <li>Fault on 'Z' or 'O' line.</li> <li>Faulty 'DOOR' button on telephone.</li> </ul>
Trades, Exit button or Fire Switch inoperative.	<ul style="list-style-type: none"> <li>Time-Clock is not running or incorrectly set (Trades button only).</li> <li>Faulty 'Z' or 'O' wires between Controller and button / switch. Check lock operates from phone.</li> </ul>

# CS109 - 1 Wiring

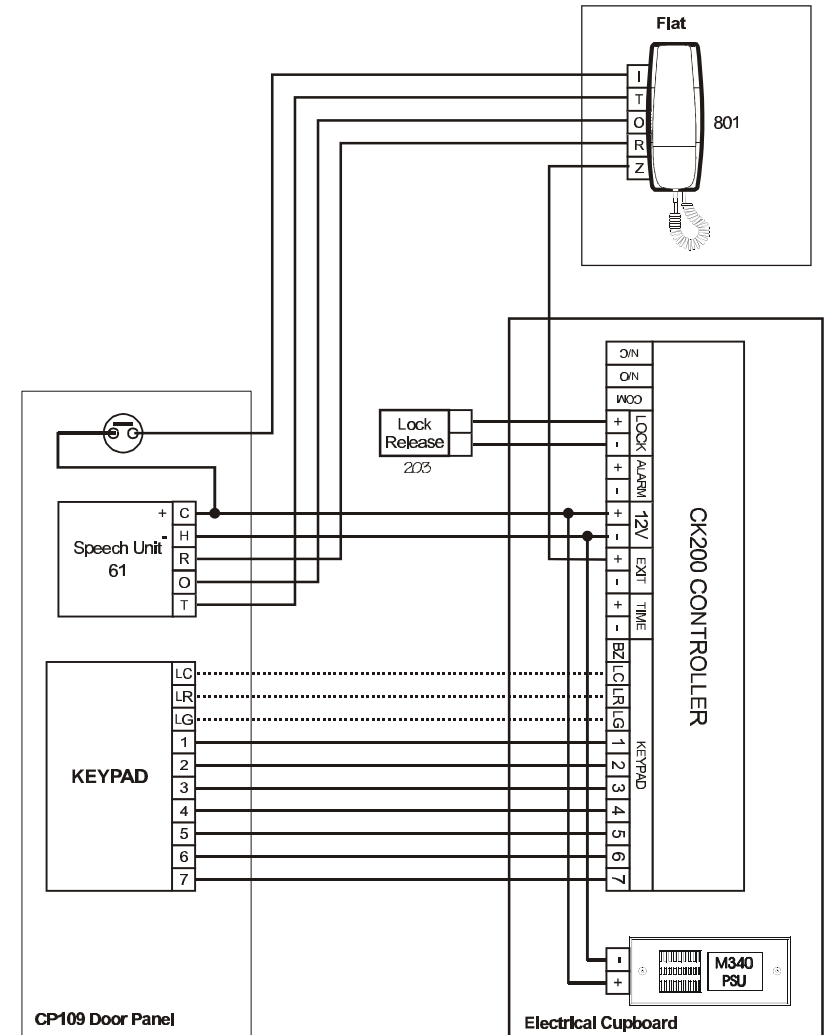

# CS109 - N Wiring

