

**NIKOLATESLA**  
**ALPHA 60**

**elica**

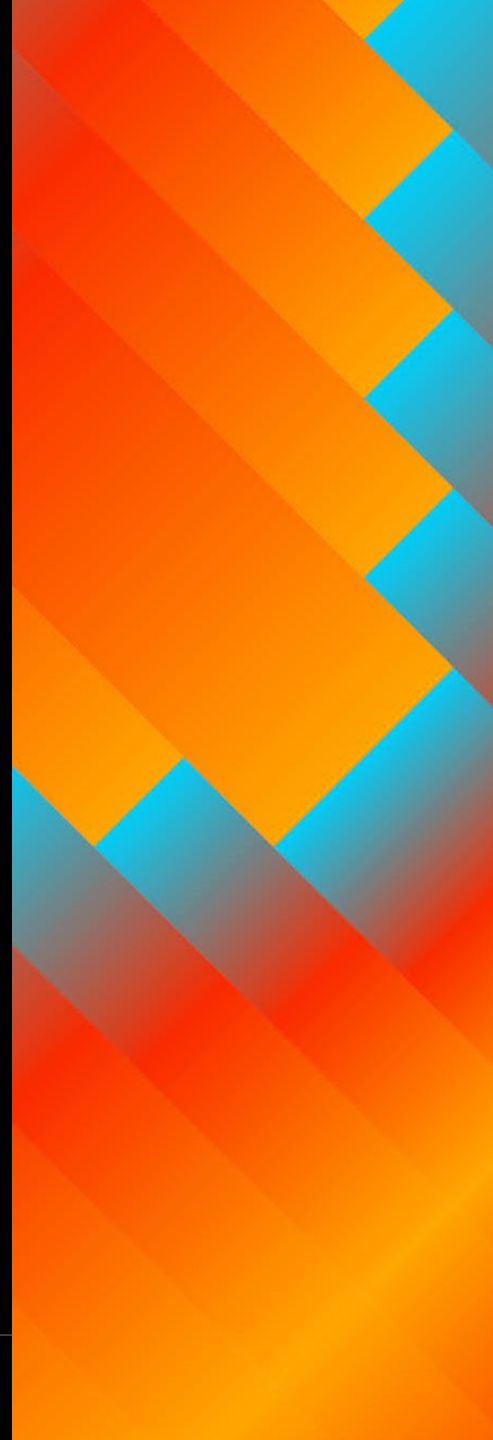







# NIKOLATESLA ALPHA 60

## THE GREEN ESSENCE OF ASPIRATION HOBS

NikolaTeslaAlpha 60 is the compact induction hob with integrated hood that integrates easily into any kitchen thanks to its design, materials and dimensions.

**The energy-saving aspiration hob.** An essential design for a personality that does not go unnoticed: the black glass and the aesthetically pleasing grid give any room a remarkable aesthetic value. Cooking is green: it only takes a few minutes to boil water, saving about 25% energy compared to standard induction hobs. It automatically detects active cooking zones and adjusts the power output. And even when the power is at maximum, silence reigns: the noise level is only 61 dB(A). NikolaTesla ALPHA 60 can be installed in 60 cm base units. The glass ceramic surface allows for easy cleaning and maintenance.



Green Induction



Long Life Filter ++

# NIKOLATESLA ALPHA 60

## TECHNICAL SHEET

Brand	ELICA
Model	ALPHA 60
Energy Class	A
Finishing	Black glass
Size	60 x 51,5 x 25 cm
<b>ASPIRATION</b>	
Configuration	Convertible
Control hood	Single Slider 4+B
Airflow (min - max - boost)	205 - 475 - 580 m <sup>3</sup> /h
Noise level (min - max - boost)	45 - 61 - 67 dB(A)
Odour filters	Ceramic, regenerable, LLF++
Grease filters (GFE)	Aluminium 5 layers
Functions	Autocapture Timer Maintenance alarm
<b>COOKING</b>	
Induction	Copreci G7
Control hob	Single Slider 9+B
Absorption	7,2 kW
Power limitation	Yes 3,1/4,5 kW
Cooking zones	4
Size cooking zones	2 - Ø 20 cm @2 kW 2 - Ø 16 cm @1,6 kW
Functions	Warming Timer Stop&Go Residual heat indicator Pot detection Child Lock Automatic Heat Up

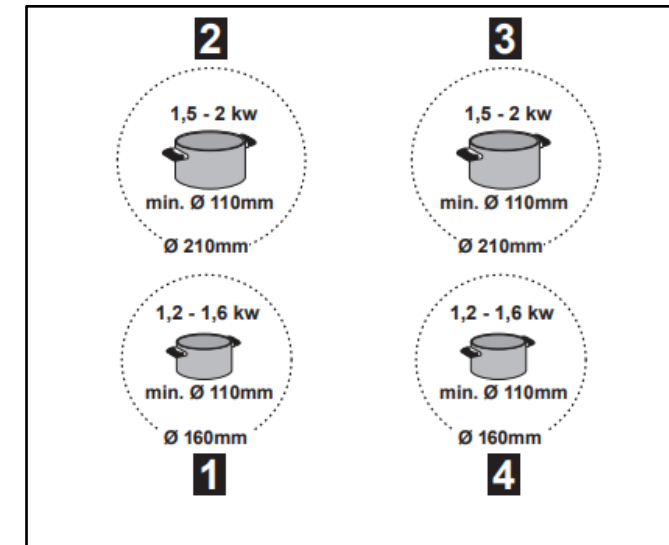

# NIKOLATESLA ALPHA 60

## PRODUCT PLUS

GREEN  
INDUCTION

### GREEN INDUCTION

Power management is now smart, to obtain excellent results even on middle power levels (especially when wanting to keep the cooking constant). For instance reaching boiling point for 2 l. of water only takes a 30 sec. more compared to standard induction hobs but it will save you about 25% of the energy. Low impact on performances but with an important energy saving.

COMFORT  
SILENCE

### COMFORT SILENCE

**The power is there, but is silent.** Kitchens are ever more being designed as open spaces, so blending all in one with the living room. Having a hood is becoming a must, as it will ensure perfect extraction of fumes and odours without generating disturbing noises. The extremely low noise level of our hoods and extractor hobs, ensure you the maximum well-being, so you can cook and hold a conversation with ease while you're busy preparing your recipe.

AUTO  
CAPTURE

### AUTOCAPTURE

**Automatic extraction, energy saving.** A function that does it all on its own. The extraction power of the hood is adjusted depending on the type of cooking that has been commenced. The smart system immediately understands when to reduce or switch it off, thus optimising your energy consumption.

# NIKOLATESLA ALPHA 60

## COOKING PRODUCT PLUS

WARMING  
MODE

### WARMING MODE

**Slow cooking, delicious results.** Conceived for slower cooking preparations, ideal when warming up milk or broths, for the preparation of custards or sauces preventing them to overheat and keeping your prepared food warm.



STOP &amp; GO

### STOP&GO

**Everything stops, everything starts again. Just with a gesture of your finger.** Need to move away from the kitchen while you are cooking? Just by a gesture, put all the functions activated on standby. All you need to do is just press a key to start them again with previous settings.

POWER  
LIMITATION

### POWER LIMITATION

**You set the limit.** During installation, this feature allows for adjustment of the maximum power limit absorbed by the appliance, so you will not risk exceeding it.



CHILD LOCK

### CHILD LOCK

**Children always safe and protected.** No worries! This function prevents the accidental switching on of cooking zones or extraction areas.



TIMER

### TIMER

**Switches off everything on its own.** All you need to do is set the minutes and the countdown starts. At the end, it will automatically switch the cooking zone off, emitting a sound signal. Just press the 'touch' control and independent timers will activate in more zones at the same time.



# NIKOLATESLA ALPHA 60

## ASPIRATION PRODUCT PLUS



### LONG LIFE FILTER ++

**Cleaner air over time.** These filters have been designed to guarantee maximum performance and odour filtering efficiency far above than average filters. Thanks to their regenerating capacity, their durability is from 3 to 5 years. No more replacements, waste or troubles in their maintenance.



### EASY TO MAINTAIN

**The perfect product with easy maintenance.** Proper maintenance and maximum hygiene, ensure a longer lifespan of the appliance. Our models have been conceived to make the replacement of grease filters and odour filters easier: all are removable, washable and replaceable.



### MAINTENANCE ALARM

**Filters KO'd? You'll be informed.** A warning light will switch on to signal out to you that grease filters and odour filters have reached their maximum saturation point. It's time for you to wash or replace them.



### DELAY SWITCH OFF

**Power off delayed, and no more worries.** With this timer, you can set the automatic switching off of the hood following a prefixed time. Keeping it on even after having cooked will eliminate any odours or humidity. No problem! It'll switch off on its own anyway!



# NIKOLATESLA ALPHA 60

## MAINTENAINCE

### EASY ACCESS

All the filters, grease and odour can be removed from the top, without unmounting the drawers.

NikolaTesla range integrates a special simplified extraction system that allows to insert from the top side of the product **2 filtering ceramic blocks**. Thanks to their regeneration properties, maintenance can be done every 3 month putting the blocks in the oven at a temperature of **200° for 45 min.**

Filters can work maintaining a constant efficiency **up to 5 Years.**

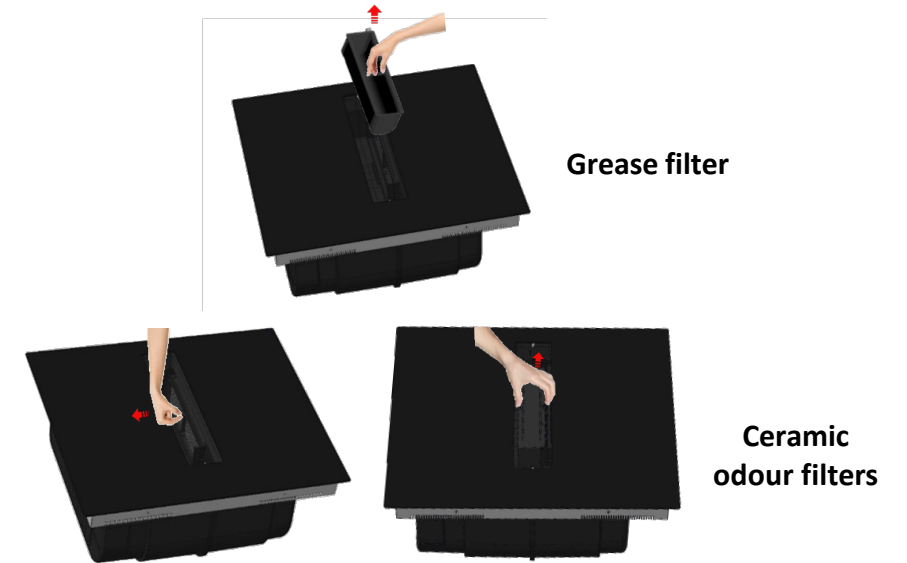

### EASY CLEANING

Every internal or external part of the product can be cleaned with no effort. Cooking residues can be removed from all the surfaces.

If some water spills inside the aspiration inlet, it can be easily be dried with a cloth, in total safe. And eventually, if the amount of water is higher, it can be easily drained form the valve positioned under the product, just letting flow the water inside a vessel.



# FILTERS

## GREASE FILTER

Aluminium 5 layers grease filter

Washable by hands or in dishwasher



The ANTI- GREASE / ODOUR / HUMIDITY ASPIRATION

HOB

## ODOUR FILTER

HP regenerable ceramic filter

Efficiency 80%

Regenerable every 3 months in the oven for 45 min. at 200°



KIT0167755

Big capability to remove the humidity in the room, both in Duct Out and Recycling version.

# NIKOLATESLA ALPHA 60 USER INTERFACE

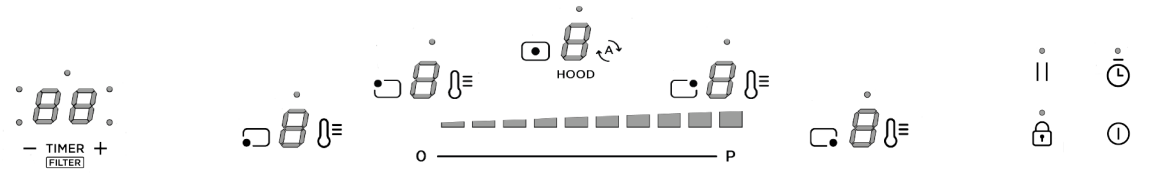

## HANDY INTERACTION

Thanks to the highly intuitive touch control panel, the cooking zones and the hood are controlled easily and intuitively: the slider touch control, both for the 4 cooking zones and for the aspiration with 4 speeds + booster. Each zone is very simple to monitor thanks to the red backlight indicators, that show the set power level. ha il menu contestuale

# INSTALLATION

## DIMENSIONS

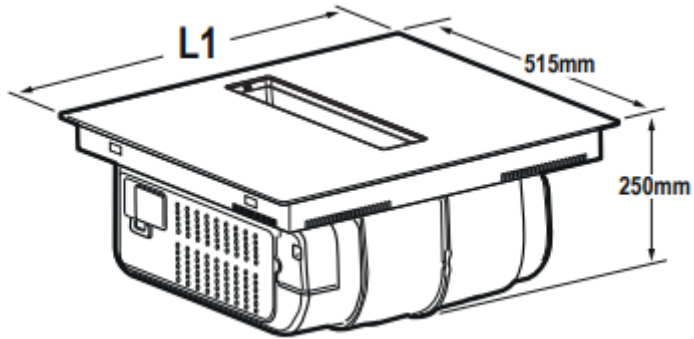

## CUT (ON TOP + FLUSH)

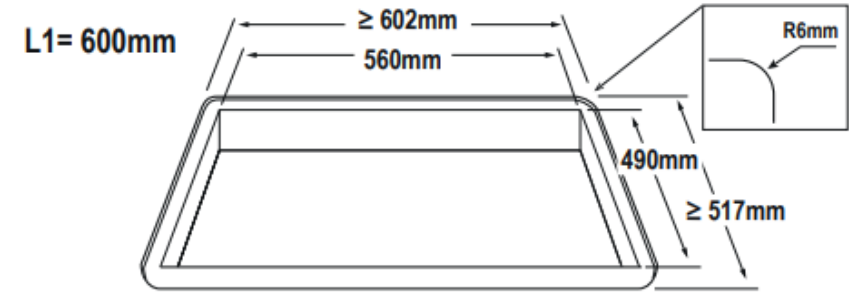

Same outlet for EXHAUST and RECYCLING versions allows more FLEXIBILITY in CONVERSION

L1= 600mm

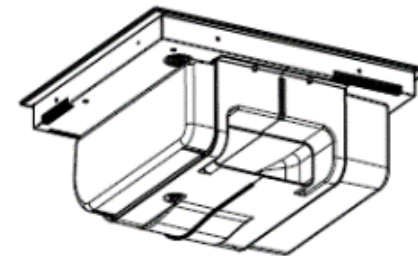
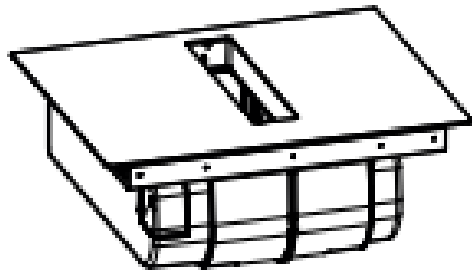

ALL PRODUCTS ARE CONVERTIBLE FROM DUCT OUT TO RECYCLING VERSION. FOR RECYCLING ARE AVAILABLE 3 OPTIONS: PLINTH IN, PLINTH OUT and BACK OUTLET

# INSTALLATION

elica

## MAXIMUM FLEXIBILITY FOR INSTALLATION

Same outlet for EXHAUST and RECYCLING versions allows more FLEXIBILITY in CONVERSION

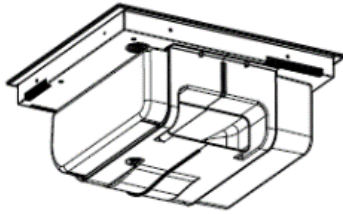

NEUTRAL EXHAUST CODE (AS BASIS for EXHAUST and RECYCLING)

+  
PIPES FOR INSTALLATION AS ACCESSORY (EXHAUST)

+  
RECYCLING CONVERSION KITS

and/or

PRESET RECYCLING SOLUTIONS with PLINTH IN/ OUT or BACK OUTLET

ALL PRODUCTS ARE CONVERTIBLE FROM DUCT OUT TO RECYCLING VERSION. FOR RECYCLING ARE AVAILABLE 3 OPTIONS: PLINTH IN, PLINTH OUT and BACK OUTLET



### BACK OUTLET

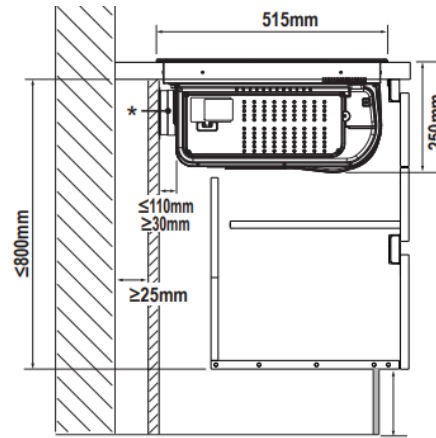

**KIT0180522**

Filtering kit back outlet

### PLINTH OUT

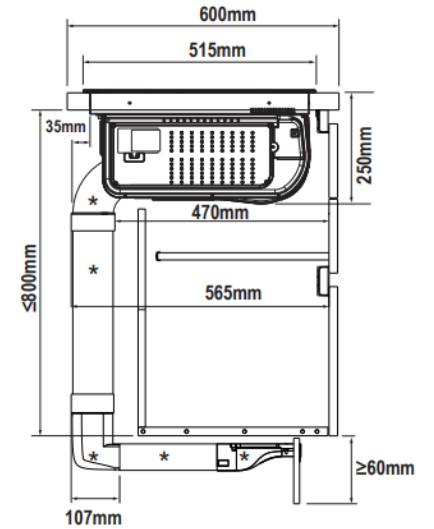

**KIT0167756**

Filtering kit plinth in



**KIT0167757**

Filtering kit plinth out

### PLINTH IN

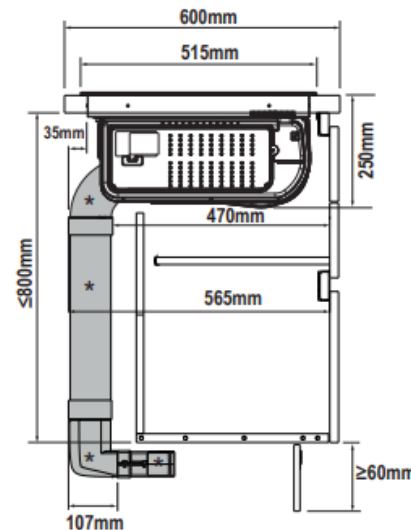

Thank you

**elica**

