

# FuseBox<sup>®</sup>

## Circuit Protection Solutions



Consumer Units



AFDDs



MCBs



RCBOs



RCDs



Surge Protection



Making Electricians Smile!



# About **FuseBox**

FuseBox design and manufacture a wide range of low voltage electrical products for domestic applications.

FuseBox aim to provide high quality, competitively priced products to the wholesaler from stock and on time.

Our product portfolio includes consumer units and circuit protection.

# About

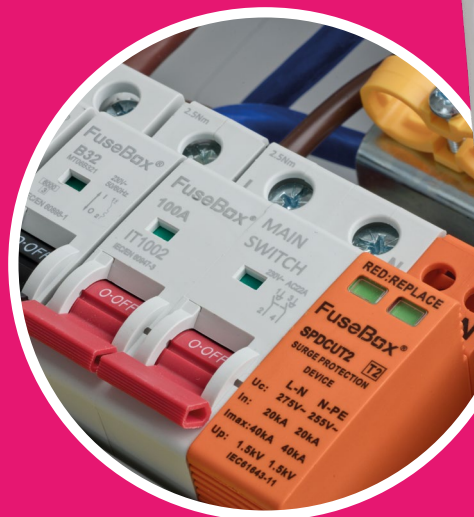



# Certificates

All FuseBox products are designed in accordance with current standards and independently tested.

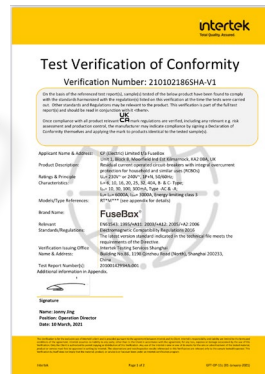

# Circuit Protection

The FuseBox circuit protection range of metal consumer units and protection devices, offers flexible versatile solutions for electrical installations.

## Design Features

- T2 surge protection
- Earth and neutral terminal bars at the top
- Removable and raised DIN rail
- Round knock-outs on all faces
- Extra height for RCBO's
- 1mm electro-galvanised steel (zinc)
- RAL 9001 powder-coated finish
- Tail clamp (ACCF)
- Circuit identification labels
- Captive screws on front cover
- IP20XC
- BS EN61439-3



\* Example shown F2006MX



# Surge Protection Consumer Units

## BS EN 61439-3

- \* Example shown F2010MX
- \* Devices and blanks to be ordered separately (pages 14-20)



### Main Switch Incomer (100A) With T2 Surge

Part No.	Usable Ways	Tail Clamp Compatible	Dimensions
F2006MX	6 WAY (100A Main Switch) SPD T2	Included	10P
F2010MX	10 WAY (100A Main Switch) SPD T2	Included	14P
F2014MX	14 WAY (100A Main Switch) SPD T2	Included	18P
F2020MX	20 WAY (100A Main Switch) SPD T2	Included	24P



**F2006MX** T2 SPD 6WAY



**F2014MX** T2 SPD 14WAY

# Surge Protection Consumer Units BS EN 61439-3



**F2029MX** T2 SPD 29WAY



**F2044MX** T2 SPD 44WAY

Double bank and Triple bank boards complete with Type 2 Surge Protection Device offers a maximum of 29 usable ways on a two row layout while the triple bank board offers a maximum of 44 usable ways on three rows.

Ideal for housing all din modular accessories such as a bell transformer and installation contactors.

## Main Switch Incomer (100A) With T2 Surge (Double Bank)

Part No.	Usable Ways	Tail Clamp Compatible	Dimensions
F2021MX	21 WAY (10/11) (100A Main Switch) SPD T2	Included	28P
F2029MX	29 WAY (14/15) (100A Main Switch) SPD T2	Included	36P

## Main Switch Incomer (100A) With T2 Surge (Triple Bank)

Part No.	Usable Ways	Tail Clamp Compatible	Dimensions
F2044MX	44 WAY (14/15/15) (100A Main Switch) SPD T2	Included	54P

# Consumer Units

## BS EN 61439-3

\* Example's shown F2004M & F2007M



### Main Switch Incomer (100A)

Part No.	Usable Ways	Tail Clamp Compatible	Dimensions
F2004M	4 WAY (100A Main Switch)	No	6P
F2007M	7 WAY (100A Main Switch)	Yes	10P
F2011M	11 WAY (100A Main Switch)	Yes	14P
F2015M	15 WAY (100A Main Switch)	Yes	18P
F2021M	21 WAY (100A Main Switch)	Yes	24P

### Main Switch Incomer (100A) (Double Bank)

Part No.	Usable Ways	Tail Clamp Compatible	Dimensions
F2022M	22 WAY (11/11) (100A Main Switch)	Yes	28P
F2030M	30 WAY (15/15) (100A Main Switch)	Yes	36P

### Main Switch Incomer (100A) (Triple Bank)

Part No.	Usable Ways	Tail Clamp Compatible	Dimensions
F2045M	45 WAY (15/15/15) (100A Main Switch)	Yes	54P

## Dual RCD



### Dual RCD with T2 Surge

Part No.	Usable Ways	Tail Clamp Compatible	Dimensions
F2010DXA	10 WAY SPD T2 (2x 80A 30mA RCD's TYPE A)	Yes	18P
F2010DX100	10 WAY SPD T2 (2x 100A 30mA RCD's TYPE A)	Yes	18P
F2016DX100	16 WAY SPD T2 (2x 100A 30mA RCD's TYPE A)	Yes	24P

## Dual RCD

Part No.	Usable Ways	Tail Clamp Compatible	Dimensions
F2011DA	11 WAY (2x 80A 30mA RCD's TYPE A)	Yes	18P
F2017DA	17 WAY (2x 80A 30mA RCD's TYPE A)	Yes	24P

## RCD incomer Type A

Part No.	Usable Ways	Tail Clamp	Dimensions
F2004RA	4 WAY (63A 30mA RCD TYPE A)	No	6P
F2007RA	7 WAY (80A 30mA RCD TYPE A)	Yes	10P

## RCD incomer Type B

Part No.	Usable Ways	Tail Clamp	Dimensions
F2004RB	4 WAY (63A 30mA RCD TYPE B)	No	6P
F2007RB	7 WAY (80A 30mA RCD TYPE B)	Yes	10P



\* Example shown F2004RA.



# Dual Tariff

## BS EN 61439-3



### Dual Tariff

Part No.	Usable Ways	Tail Clamp	Dimensions
F2014DT	14 WAY (7/7) 2x 100A Main Switch	No	18P

### Dual Tariff (Double Bank)

Part No.	Usable Ways	Tail Clamp	Dimensions
F2020MDT	20 WAY (10/10) 2x 100A Main Switch	Yes	28P
F2030MDT	30 WAY (15/15) 2x 100A Main Switch	Yes	36P



F2030MDT 2x MAIN SWITCH 30WAY 15/15

# EV Charger Distribution



## EV Charger Distribution With T2 SPD

Part No.	Description
EV32AX	100A M/S 32A (30mA 2P RCBO TYPE A + SPD T2)
EV40AX	100A M/S 40A (30mA 2P RCBO TYPE A + SPD T2)

## EV Charger Distribution

Part No.	Description
EV32A	100A M/S 32A (30mA 2P RCBO TYPE A)
EV40A	100A M/S 40A (30mA 2P RCBO TYPE A)

## EV Charger Distribution (Type B)

Part No.	Description
EV32B	63A (30mA TYPE B RCD + 32A MCB)
EV40B	63A (30mA TYPE B RCD + 40A MCB)

## Garage Unit (Type A)

Part No.	Description
F100GRA	63A 30mA RCD + 6A & 16A MCB's TYPE A
F200GRAX	63A 30mA RCD + 6A & 16A MCBs TYPE A + SPD T2



F200GRAX T2 GARAGE UNIT



F100GRA GARAGE UNIT

# Surge Protection

Suitable for TN,  
TNC-S, TNC and  
TT systems



## Surge Protection (Retro Fit) Enclosed

Part No.	Description
F2MSPD1	IN LINE T1 SPD &100A MAIN SWITCH IN A METAL ENCLOSURE
F1M2SPD	IN LINE T2 SPD & 100A MAIN SWITCH IN A METAL ENCLOSURE



## Surge Protection Consumer Unit Kits

Part No.	Description
SPDCUKITT1	T1 SPD DEVICE (36mm) WITH 63A MCB AND CABLES
SPDCUKITT2	T2 SPD DEVICE (18mm) WITH 32A MCB AND CABLES

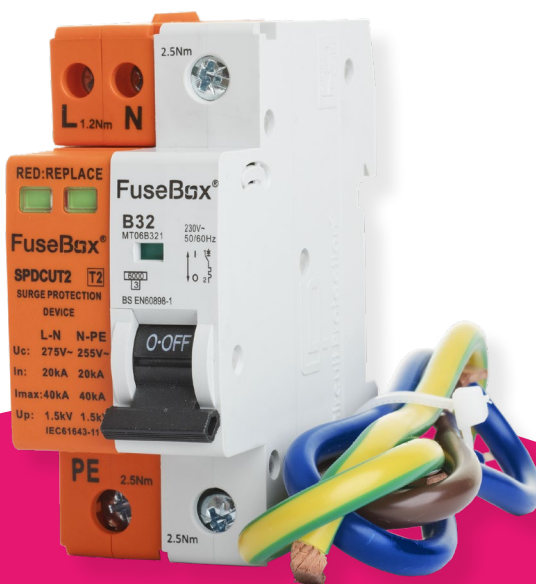

## Flush Mounting Frames

Part No.	Description	Module
AFMF14	FLUSH FIT FRAME	14
AFMF18	FLUSH FIT FRAME	18
AFMF24	FLUSH FIT FRAME	24



## Surface Spacers

Part No.	Description	Module
AFSS14	14P SURFACE SPACER (METAL) 30mm	14
AFSS18	18P SURFACE SPACER (METAL) 30mm	18
AFSS24	24P SURFACE SPACER (METAL) 30mm	24



## Metal Enclosures

Part No.	Description
F1004E	4 MOD ENCLOSURE (EARTH & NEUTRAL TERMINAL BARS)
F2048E	54 MODULE ENCLOSURE 3 BANK (E+N TERMINALS)





## Changeover Switch

Part No.	Description
SCO125	125A CHANGEOVER SWITCH 1P + N IN METAL ENCLOSURE
SCO125SWB	125A CHANGEOVER SWITCH AND BUSBAR (DIN RAIL MOUNTING)





# RCD 2P

## BS EN 61008-1

### Type A

Part No.	Description
RTA250302	TYPE A 25A 30mA 2P RCD
RTA400302	TYPE A 40A 30mA 2P RCD
RTA630302	TYPE A 63A 30mA 2P RCD
RTA800302	TYPE A 80A 30mA 2P RCD
RTA801002	TYPE A 80A 100mA 2P RCD
RTA100302	TYPE A 100A 30mA 2P RCD
RTA1001002S	TYPE A 100A 100mA 2P RCD "S" TYPE Time Delayed



\* Example shown RTA630302



### Type B

Part No.	Description
RTB630302M	TYPE B 63A 30mA 2P RCD (36mm)

# MCB 6kA 1P

## BS EN 60898-1

### B Curve

Part No.	Description
MT06B061	6A B CURVE MCB 6kA 1P
MT06B101	10A B CURVE MCB 6kA 1P
MT06B161	16A B CURVE MCB 6kA 1P
MT06B201	20A B CURVE MCB 6kA 1P
MT06B251	25A B CURVE MCB 6kA 1P
MT06B321	32A B CURVE MCB 6kA 1P
MT06B401	40A B CURVE MCB 6kA 1P
MT06B451	45A B CURVE MCB 6kA 1P
MT06B501	50A B CURVE MCB 6kA 1P
MT06B631	63A B CURVE MCB 6kA 1P

### C Curve

Part No.	Description
MT06C061	6A C CURVE MCB 6kA 1P
MT06C101	10A C CURVE MCB 6kA 1P
MT06C161	16A C CURVE MCB 6kA 1P
MT06C201	20A C CURVE MCB 6kA 1P
MT06C251	25A C CURVE MCB 6kA 1P
MT06C321	32A C CURVE MCB 6kA 1P
MT06C401	40A C CURVE MCB 6kA 1P
MT06C501	50A C CURVE MCB 6kA 1P
MT06C631	63A C CURVE MCB 6kA 1P



\* Examples shown MT06B501 & MT06C321

# RCBO Mini 6kA (1P+N Switched)

## (Type A) BS EN 61009-1

### B Curve

Part No.	Description
RTAMB06	MINI 6A B RCBO 2P 30mA 6kA TYPE A
RTAMB10	MINI 10A B RCBO 2P 30mA 6kA TYPE A
RTAMB16	MINI 16A B RCBO 2P 30mA 6kA TYPE A
RTAMB20	MINI 20A B RCBO 2P 30mA 6kA TYPE A
RTAMB25	MINI 25A B RCBO 2P 30mA 6kA TYPE A
RTAMB32	MINI 32A B RCBO 2P 30mA 6kA TYPE A
RTAMB40	MINI 40A B RCBO 2P 30mA 6kA TYPE A

### C Curve

Part No.	Description
RTAMC06	MINI 6A C RCBO 2P 30mA 6kA TYPE A
RTAMC10	MINI 10A C RCBO 2P 30mA 6kA TYPE A
RTAMC16	MINI 16A C RCBO 2P 30mA 6kA TYPE A
RTAMC20	MINI 20A C RCBO 2P 30mA 6kA TYPE A
RTAMC25	MINI 25A C RCBO 2P 30mA 6kA TYPE A
RTAMC32	MINI 32A C RCBO 2P 30mA 6kA TYPE A
RTAMC40	MINI 40A C RCBO 2P 30mA 6kA TYPE A

# RCBO 6kA (Type A)

## BS EN 61009-1



\* Examples shown RTA060630B & RTAMB06

Part No.	Description
RTA060630B	6A B RCBO 30mA 6kA TYPE A
RTA061030B	10A B RCBO 30mA 6kA TYPE A
RTA061630B	16A B RCBO 30mA 6kA TYPE A
RTA062030B	20A B RCBO 30mA 6kA TYPE A
RTA062530B	25A B RCBO 30mA 6kA TYPE A
RTA063230B	32A B RCBO 30mA 6kA TYPE A
RTA064030B	40A B RCBO 30mA 6kA TYPE A
RTA064530B	45A B RCBO 30mA 6kA TYPE A
RTA065030B	50A B RCBO 30mA 6kA TYPE A

# Arc Fault Detection Device (AFDD)



- FuseBox combined AFDD/ RCBO (1P+N) SWITCHED
- Fully compliant and 3rd party tested to BS EN 62606 / IEC 61009-1
- LED Fault indication
- Fits all FuseBox consumer units
- Replaces any FuseBox RCBO where additional ARC protection may be required
- Used for the protection against ARC FAULTS (SERIES AND PARALLEL), overload, short circuit and earth leakage
- Type A for AC and pulsating DC sensitivity
- Short circuit capacity of 6kA with a maximum rating of 40A



## B Curve

Part No.	Description
AFDD060630B	AFDD RCBO 6A 30mA 1P+N TYPE A
AFDD061030B	AFDD RCBO 10A 30mA 1P+N TYPE A
AFDD061630B	AFDD RCBO 16A 30mA 1P+N TYPE A
AFDD062030B	AFDD RCBO 20A 30mA 1P+N TYPE A
AFDD062530B	AFDD RCBO 25A 30mA 1P+N TYPE A
AFDD063230B	AFDD RCBO 32A 30mA 1P+N TYPE A
AFDD064030B	AFDD RCBO 40A 30mA 1P+N TYPE A

# Accessories

## Bell Transformer

Part No.	Description	Module
ABTR	BELL TRANSFORMER 8V 1A	2
ABTR16	BELL TRANSFORMER 16V/0.5A	2



## Module Blanks

Part No.	Description	Module
ADRB	MODULE BLANK DINRAIL MOUNTING (1PC)	1
AMBM	MODULE BLANKS METAL (6PCS)	6
AMBP	MODULE BLANKS ABS (12 PCS)	12

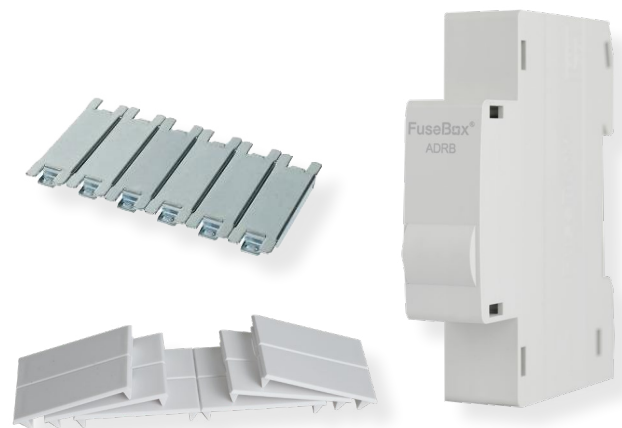

## Tail Clamp

Part No.	Description
ACCF	TAIL CLAMP FOR LIVE AND NEUTRAL UP TO 25mm <sup>2</sup> (TO FIT FUSEBOX CONSUMER UNITS ON PAGES 7-9)
ACCFT1	TAIL CLAMP FOR T1 SPD

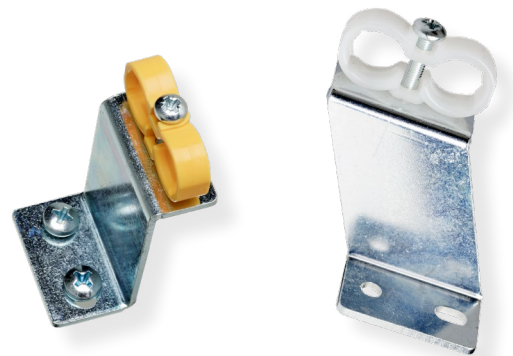

## Lock Off

Part No.	Description
AFBL	LOCK ONLY. NO PADLOCK.
FBLOK	LOCK OFF KIT INC. PADLOCK (MCB, MAIN SWITCH & RCBO)





## Glands

Part No.	Description
AGSTRIP	GROMMET STRIP (5M)
APIMG	PUSH IN MEMBRANE GLAND (QTY 20 MIXED)
AREG	REAR ENTRY GLAND (QTY 5)
G32T	32mm TAIL GLAND FOR 25mm <sup>2</sup> LIVE & NEUTRAL, AND 16mm <sup>2</sup> EARTH (QTY 1)



## Main Switch / Isolator

Part No.	Description	Module
IT1002	100A 2 POLE ISOLATOR	2
IT1002U	100A 2 POLE CONNECTOR	2



## kWH Meter (MID Approved)

Part No.	Description
KWH1M45	kWH METER 45A 230V

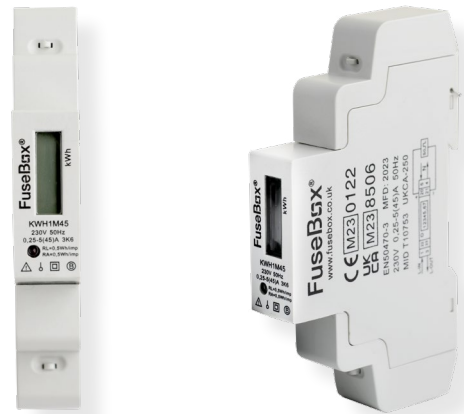

## Time Clock

Part No.	Description
TD1	DIGITAL TIME CLOCK 7 DAY 1CH 150HR RESERVE



# Fused Switch

Part No.	Description
SF0100	100A FUSED SWITCH (inc. 63A, 80A, 100A gG Fuses)
SF0100RA	100A 100mA Time delayed RCD Type A + Fuse Holder (inc. 63A, 80A, 100A gG Fuses)
FMS080	80A FUSED SWITCH (inc. cable shroud and ME080A Fuse)



# Installation Contactors

Supplied With 2x9mm Heat Dissipation Spacers (+1)



Part No.	Description	Module
INC202	20A 2P N/O 230V	1 (+1)
INC254	25A 4P N/O 230V	2 (+1)
INC402	40A 2P N/O 230V	2 (+1)
INC632	63A 2P N/O 230V	2 (+1)
INC634	63A 4P N/O 230V	3 (+1)

# Dimensions

6P, 10P, 14P, 18P & 24P

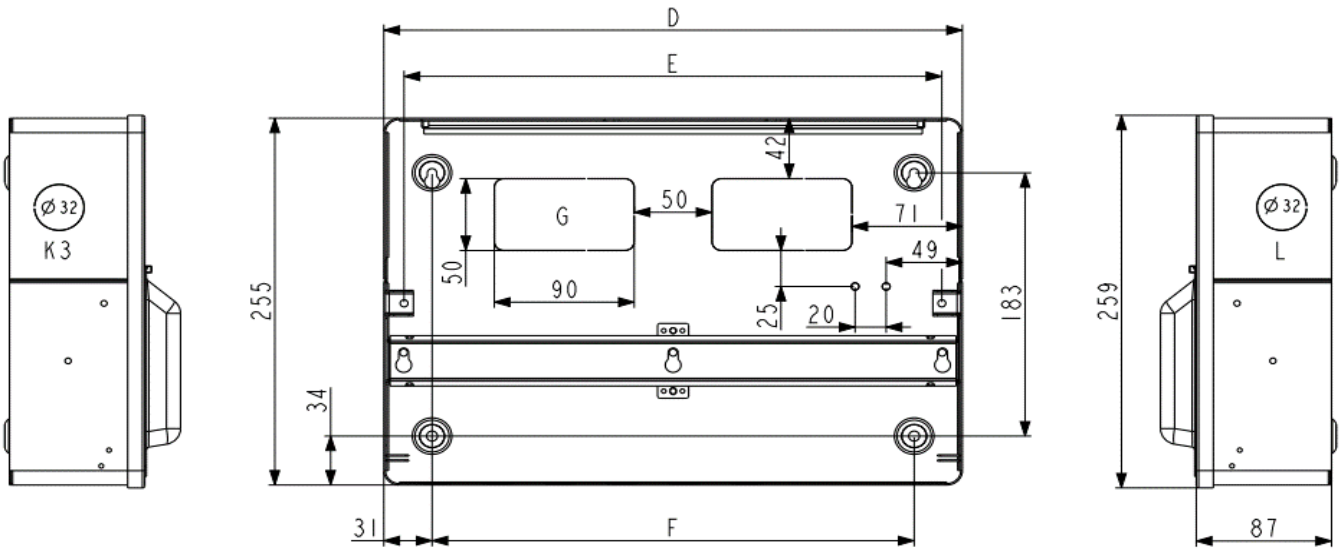

	6P	10P	14P	18P	24P
A	162	234	306	378	486
B	144	216	288	360	468
C	140	212	284	356	464
D	156	228	300	372	480
E	130	202	274	346	454
F	94	166	238	310	418
G	1	2	2	2	3
H1	1	1	3	5	7
K1	1	2	2	2	2
H2	1	2	4	6	8
K2	1	2	2	2	2
K3	1	1	1	1	1
L	1	1	1	1	1

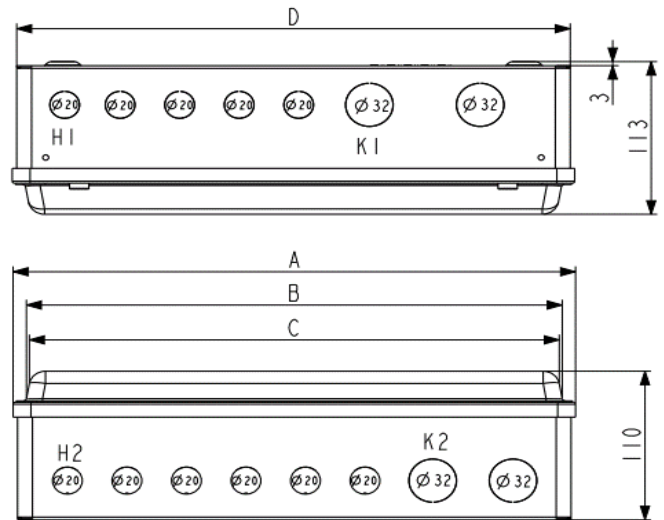

# Dimensions

28P & 36P

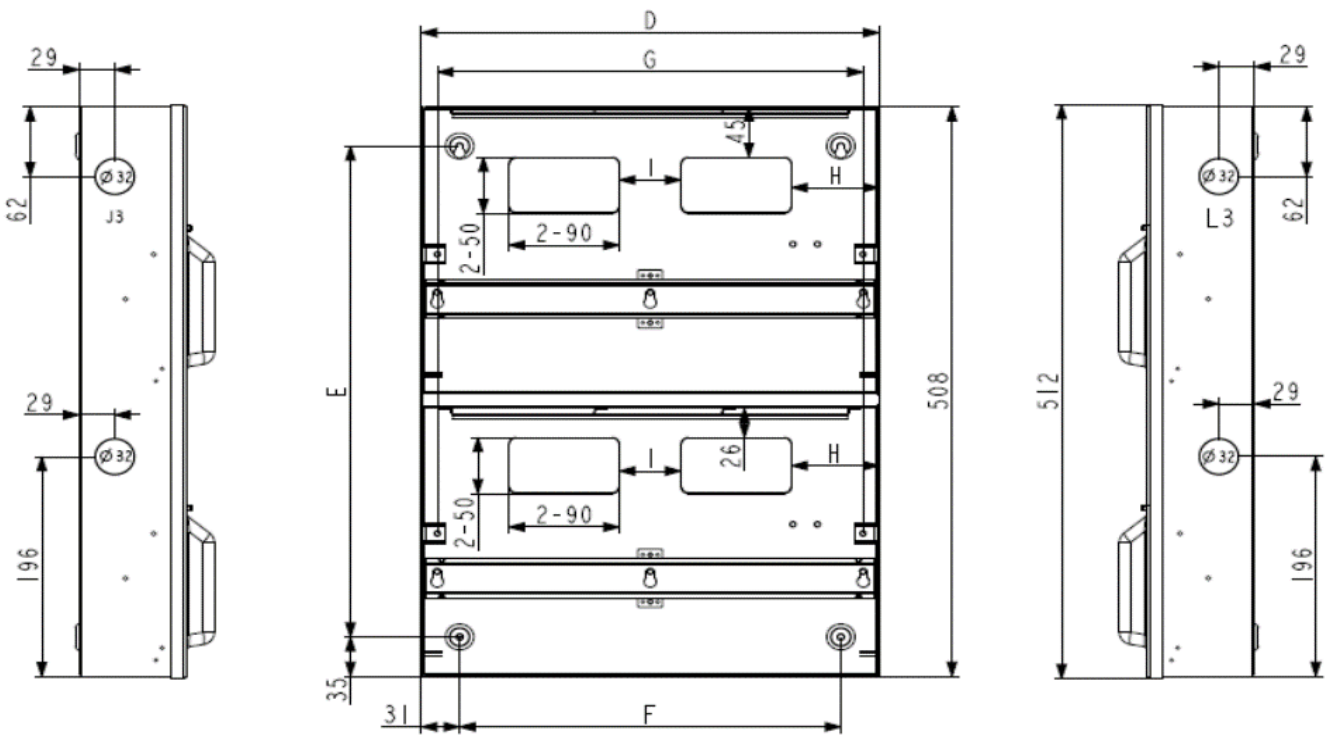

	28P	36P
A	306	378
B	288	359
C	284	356
D	300	372
E	438	438
F	238	310
G	274	346
H	52.5	71
I	15	50
J1	3	5
L1	2	2
J2	4	6
L2	2	2
J3	2	2
L3	2	2

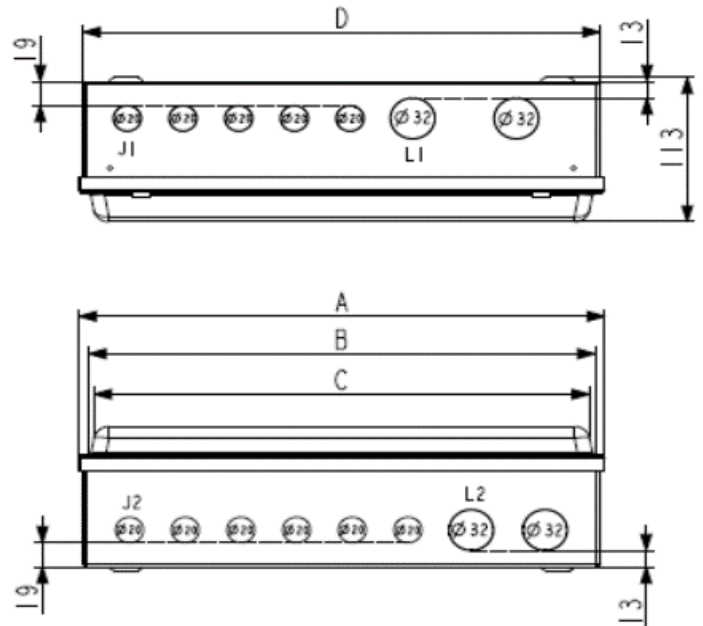

# Dimensions

54P

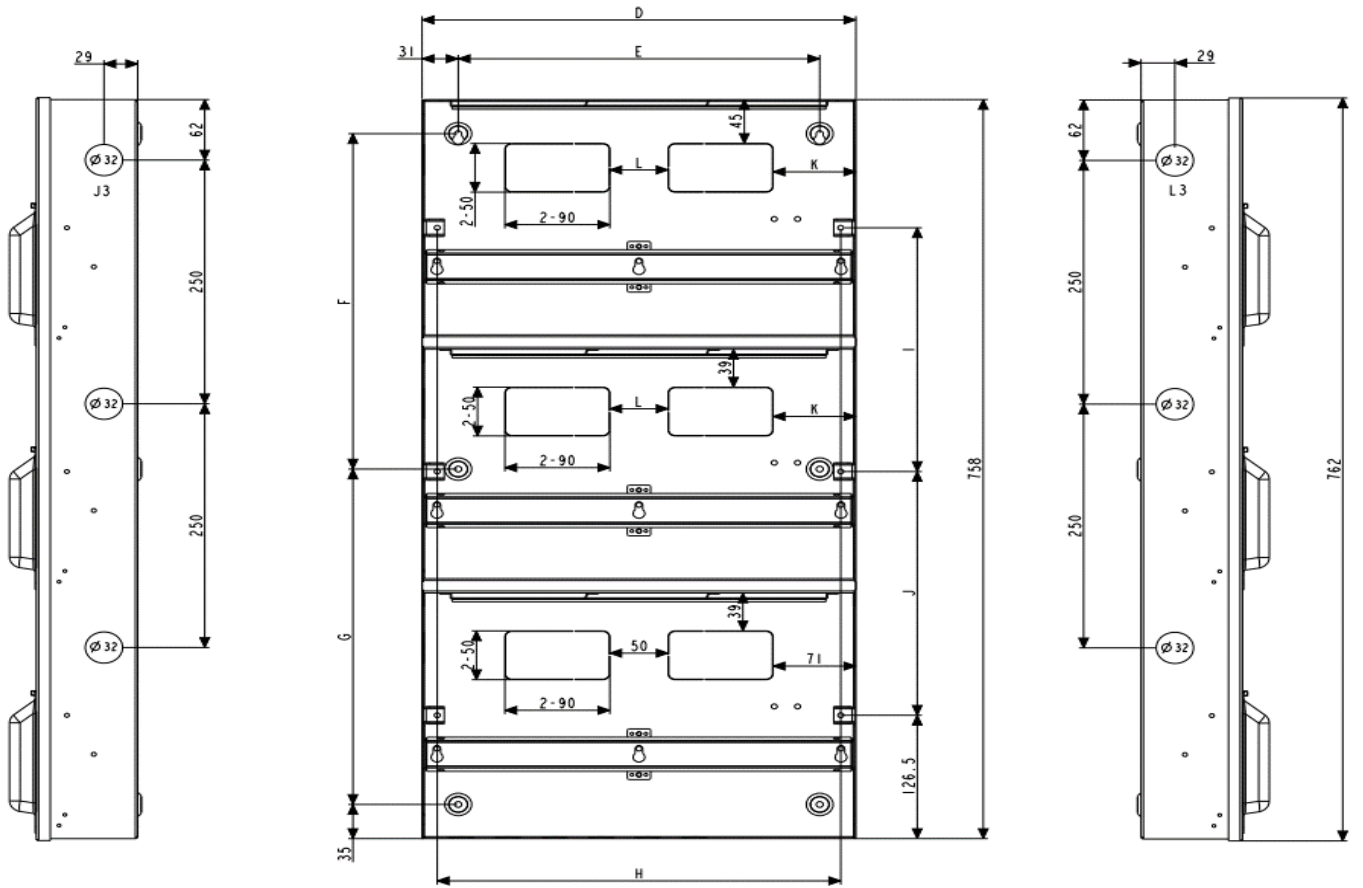

	54P
A	378
B	359
C	356
D	372
E	310
F	344
G	344
H	346
I	250
J	250
K	71
L	50
J1	7
L1	1
J2	6
L2	2
J3	3
L3	3

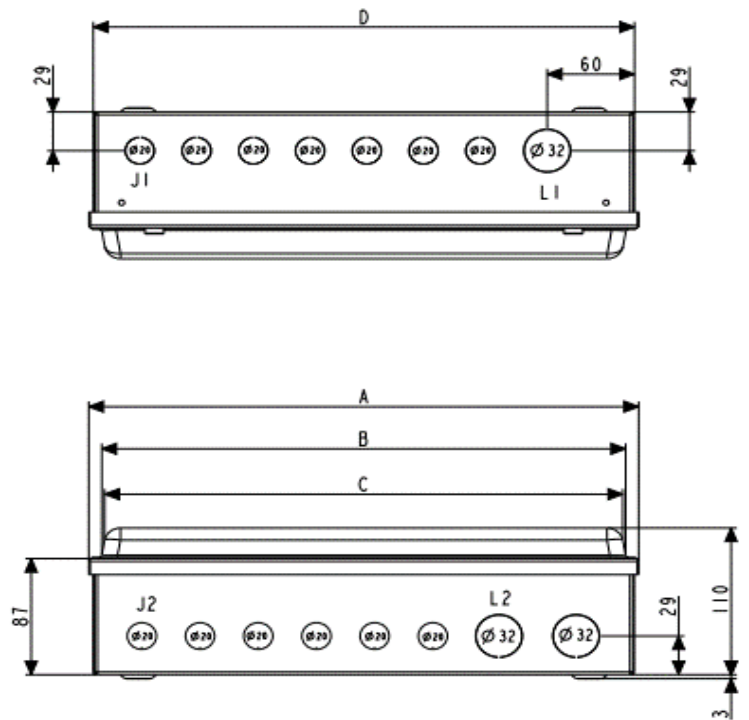





# Ticking All The Boxes!

When you buy from a specialist... expect something special – the FuseBox range of metal consumer units and protection devices.



Photography is for illustrative purposes only and the product you receive may differ slightly due to continued product development. FuseBox is the trading name of CP (Electric) Ltd. All goods are sold subject to CP (Electric) Ltd terms and conditions of sale.



# FuseBox®

Making Electricians Smile!

fusebox.co.uk | 01563 533 554 |      



Find Your Local Stockist

