

RTAM MINI RCBO 6kA 1P+N (Switched Neutral)
Instruction Leaflet DOC:RCBOMINI2022

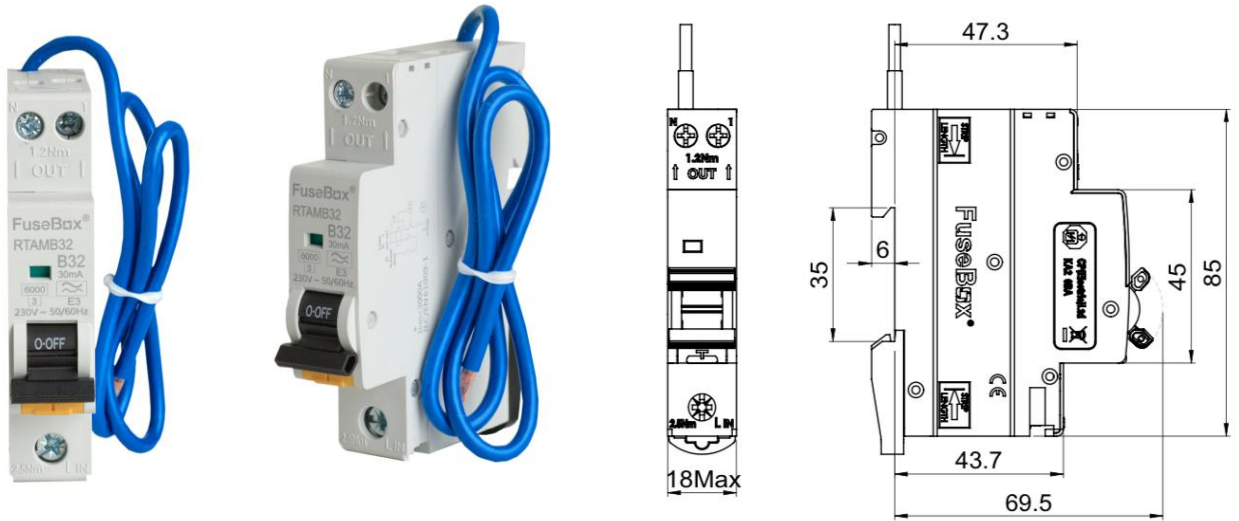

Technical information



Wiring Diagram

Series	RTAM
Rating (A)	6, 10, 16, 20,25, 32, 40
Tripping curve	B, C
Number of Poles	1P + N (switched neutral)
Residual Operating Current(IΔn)	30mA
Type	A
Voltage(V)	230V
Frequency	50/60Hz
Rated short circuit capacity	6kA
IP RATING	IP20 EN 60529
Torque	2.5Nm / 1.2Nm
Maximum cable capacity	16mm ² (Lin) 10mm ² (Lout Nout)
Neutral cable length	450mm (can be cut to suit)
Complies with	IEC 61009-1 IEC 61009-2-2

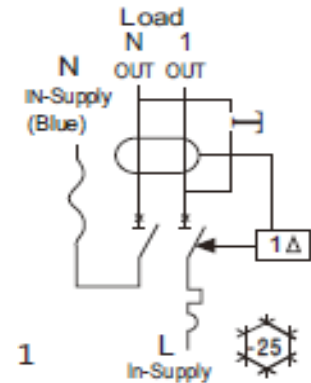

MINI RCBO series (RTAM)

MINI RCBO with switched LINE and NEUTRAL. Used for the protection against overload, short circuit and earth leakage. Type A for AC and pulsating DC sensitivity with a short circuit capacity of 6kA with a maximum rating of 40A.

Compact in size increasing working space within a FuseBox consumer unit making installation, connection and testing easier and quicker.

Flying Neutral cable can be cut to suit but should be terminated.

TESTING:

Line and Neutral conductors SHOULD BE disconnected for IR (insulation resistance).

NEUTRAL CABLE CSA	
6A	2.5 mm ²
10A	2.5 mm ²
16A	2.5 mm ²
20A	2.5 mm ²
32A	4.0 mm ²
40A	4.0 mm ²

After installation and testing of this product it is essential that the INSTRUCTION LEAFLET is available for reference

- 1b RCBO must be installed by a qualified electrician in accordance with the current IET Wiring Regulations BS 7671.
- 1c Total load must not exceed the rating of the RCBO or any additional limitation.

2 Installation

- 2a RCBO range designed to fit FuseBox consumer units and modular enclosures.
- 2b 35mm top hat din rail mounting.
- 2c Clip securely on to the din rail making sure the din rail clip at the bottom is pushed in, locking the RCBO onto the din rail, ensure lever is in the OFF position.
- 2d Cut, dress and connect cables as shown in the **wiring diagram**.

Lin (Line) terminal connect to the bus bar.

Neutral flying lead to the neutral terminal bar (can be cut to size to suit application).

Connect the load to the L OUT and N OUT terminals at the top of the RCBO and the Load earth to the terminal bar.

3 Connections

- 3a **Before powering up the circuit check all connections are TORQUED.**
Loose connections cause fires!!!!

4 Testing

- 4a On completion of the installation, it must be tested in accordance with the latest edition of the IET Wiring Regulations for Electrical Installations (BS 7671).

Operation of the TEST button on RCBO

When newly fitted systems do not trip on the TEST button or using the RCD tester the problem is normally caused by an earth to neutral fault on the circuit (PME supply).

Installers can easily check the RCBO by removing the LOAD connections on the RCBO and applying power. If the TEST button works the fault is in the circuit.

RCBO TEST

RCBOs ARE MANUFACTURED IN ACCORDANCE WITH **IEC 61009-1** AND MUST BE TESTED TO THIS SPECIFICATION USING A CALIBRATED TEST METER.

General type

0.5IΔn	RCBO will not trip
1Δn	RCBO must trip within 300ms
5IΔn	RCBO must trip within 40ms

What to do if a RCBO trips

- 1 Reset tripped RCBO to **ON** position
- 2 If RCBO trips again then disconnect all appliances connected to this circuit.
- 3 Switch RCBO to **ON** position and connect 1 appliance at a time to see which one trips the RCBO.
- 4 Once the faulty appliance has been identified, **DO NOT USE** appliance until it has been checked.
- 5 Switch RCBO to **ON** position.
- 6 **If fault does not clear phone a qualified electrician to check installation**

Environment

WASTE ELECTRICAL PRODUCTS SHOULD NOT BE DISPOSED OF IN HOUSEHOLD WASTE. CONTACT YOUR RETAILER OR LOCAL AUTHORITY FOR RECYCLING INFORMATION



www.fusebox.co.uk

FuseBox®