

COMMISSIONING

To check whether the valve is operating correctly, carry out the following checks after the system is filled and vented. Ensure that the override lever is in the Auto position and the insert guide is removed.

If the valve is fitted on a HW circuit.

Set the cylinder thermostat to maximum or turn the HW on at the programmer. The valve should open. The boiler should fire, the pump run and the pipe on the Port B side should get hot.

If the valve is fitted on a CH circuit.

Set the room thermostat to maximum or turn the CH on at the programmer. The valve should open. The boiler should fire, the pump run and the pipe on the Port B side should get hot.

Reset both thermostats and the programmer to their normal settings.

Please note the above assumes that both programmer and thermostats are being used. If this is not the case, ignore the action described for the item not fitted.

SPARES

The actuator and body for the Z222XL zone valve (with auxiliary switch) can be purchased separately as spares or as replacement parts (see page 1).

HORSTMANN RESERVE THE RIGHT AT ANY TIME AND WITHOUT NOTICE TO CHANGE ANY PRODUCT OR INFORMATION CONTAINED WITHIN THIS LEAFLET.

ZONEPLUS Z222XL
INSTALLATION AND
COMMISSIONING INSTRUCTIONS



HORSTMANN

APPLICATION

The Z222XL valve with auxiliary switch has been designed to control the water circulation in fully pumped systems, which employs a single pump for both Hot water and Central heating circuits, by allowing the flow to either or both circuits using separate valves.

INSTALLATION AND CONNECTION SHOULD ONLY BE CARRIED OUT BY A SUITABLY QUALIFIED PERSON AND IN ACCORDANCE WITH THE CURRENT EDITION OF THE IEE WIRING REGULATIONS. A CLASS 'A' SWITCH (HAVING CONTACT SEPARATION OF AT LEAST 3MM IN ALL POLES) MUST BE INCORPORATED IN THE FIXED WIRING AS A MEANS OF DISCONNECTING THE SUPPLY, NORMALLY AT THE CONSUMER UNIT. THE SYSTEM MUST BE APPROPRIATELY FUSED.

WARNING : ISOLATE MAINS SUPPLY BEFORE COMMENCING INSTALLATION

SPECIFICATION

Motor supply voltage: 230V AC, 50Hz

Power consumption: <6W

Lead supplied: 1 meter 4 core cable. Industry standard colours used

No earth connection required as unit is double insulated

Operating flow temperature: -5°C to 88°C

Switch rating: 3Amps

Maximum ambient temperature: 50°C

Maximum static pressure: 8.6 Bar

Maximum differential pressure: 0.5 Bar

Pipe fitting size: 22mm compression

Actuator: Maximum time to power open - 20 seconds

Maximum time to spring close - 10 seconds

Override lever: For manual operating to open valve for system draining or filling. During normal operation, the lever must be in the auto position.

(See diagram opposite).

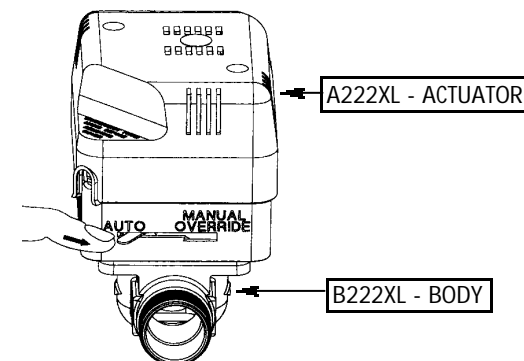

The Z222XL consists of a 2 port valve body (Ref.B222XL) to which a self-contained actuator (Ref.A222XL) is attached.

OPERATION

Valve position - In the event that mains power is disconnected the valve automatically spring-returns to the closed position (Port A).

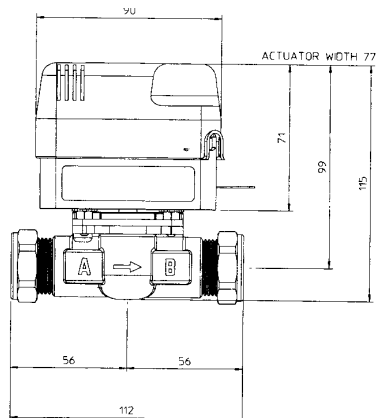

INSTALLATION

POSITIONING OF VALVE

On new installations fit the Z222XL valve ensuring that the actuator head is NOT below the horizontal level of the pipework and that flow is in the direction of the arrow. Also check that neither the open vent or the cold feed are isolated. This will ensure system and product safety at all times. Remember to make allowances for working, maintenance and replacement.

FITTING OF VALVE BODY TO PIPEWORK

Fit the valve body using the 22mm compression fittings provided. Tighten the compression nuts sufficiently to make a watertight seal, only gripping the valve by its body. Take care not to over tighten.

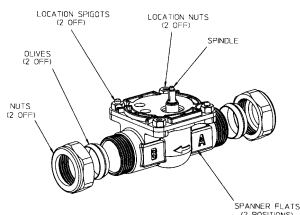

FIT ACTUATOR TO VALVE BODY

Position the actuator on the valve body lining up the valve spindle with the 'D' shape slot. A yellow guide strip has been inserted behind the Override lever to assist installation, please remove the guide once the actuator installation is complete and before the system is used. The actuator guide holes should line up with the spigots on the valve body.

Fix with the screws provided and tighten lightly. The override lever should now be on the Port B side. Set the override lever to manual. Fill, test and thoroughly flush the system (see diagram and instruction under the Specification section located on page 4 of this guide).

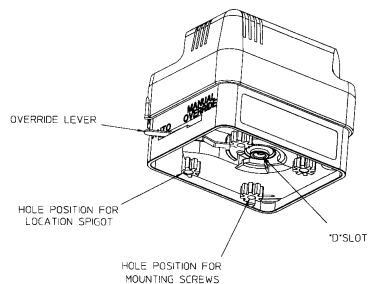

WIRING CONNECTIONS

The 4 core cable fitted to the actuator can now be connected to the system following the simple colour-coded guide below.

IF FITTING TO A HW ZONE:	
Wire Colour	System Connection
Blue	Any Neutral supply.
Brown	'Call' terminal of cylinder stat if fitted, otherwise the HW ON terminal of the programmer.
Orange	Live terminal of pump and boiler
Grey	Any permanent live supply.

IF FITTING TO A CH ZONE:	
Wire Colour	System Connection
Blue	Any Neutral supply.
Brown	'Call' terminal of room stat if fitted, otherwise the CH ON terminal of the programmer.
Orange	Live terminal of pump and boiler
Grey	Any permanent live supply.

No earth connection is required. Ensure all connections are good and the screw secure. A torque of 0.75Nm is recommended for fixing the wires in place. NOTE: In the event that the Z222XL is being used in an unconventional system, the above connections may be incorrect. In this case, please seek advice.

