

LEDLITE™ Installation Sheet



LTDCB18CCT

LED DIE CAST

IP65 Round Bulkhead
CCT Changeable / Tri Wattage
9W/14W/18W

UK CA CE RoHS F 220-240V

These instructions should be read carefully and retained after installation for further reference and maintenance.

SAFETY

- Before installation, ensure that the mains supply to the luminaire is switched off and the circuit supply fuses are removed or circuit breaker turned off.
- It is recommended that a qualified electrician is consulted or used for the installation of this luminaire and installed to the current edition of the IEE wiring regulations.
- Check that the total load on the circuit, including this luminaire, does not exceed the rating of the circuit cable, fuse or circuit breaker.

RATINGS

- This luminaire is of Class I construction and it requires an earth connection
- IP65 rated
- F marked, suitable for installation on normal flammable surfaces
- Working Temp.: -15°C to 40°C
- 220-240V/AC rated
- CE Approved

DIMENSIONS:

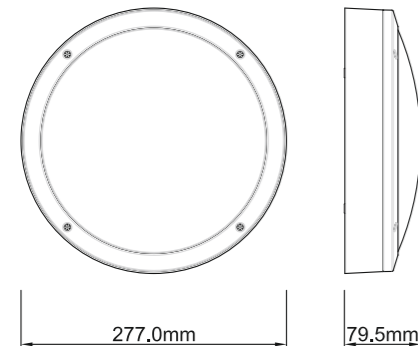

WIRING DIAGRAM:

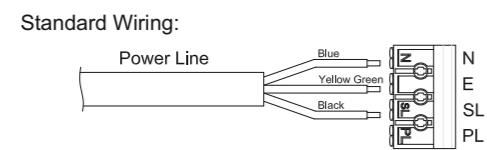

When used with Quick Plug-in LTEM Emergency Pack:

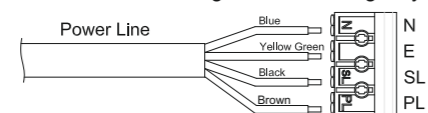

CCT & POWER ADJUSTABLE:

Switch off the mains supply before changing power or CCT

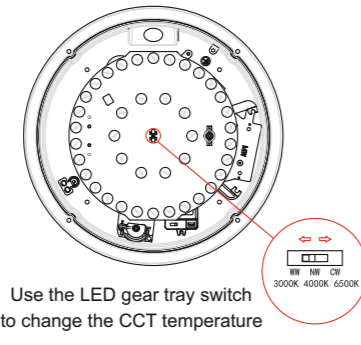
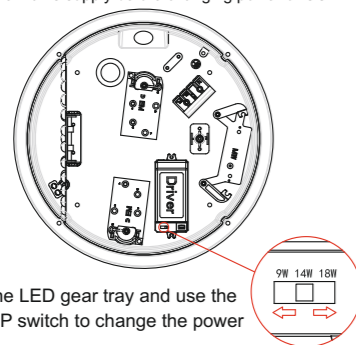

TECHNICAL SPECIFICATIONS:

- Input Voltage: 220-240V/AC
- Tri-Power Selectable: 9W / 14W / 18W
- Light Output: 9W - 900lm
14W - 1400lm
18W - 1800lm
- CCT Changeable (switch):
3000K/4000K/6500K

- CRI > 80
- IP Rating: IP65
- Protection Class: Class I
- Housing: Die Casting Body & Diffuser
- Operating Temp.: -15°C to +40°C
- Dimensions: Diameter 277mm / depth 79.5mm
- Warranty: 5 years

INSTALLATION INSTRUCTIONS:

Switch off the mains supply before installation.

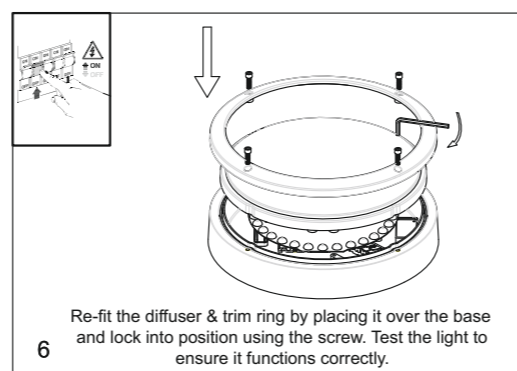
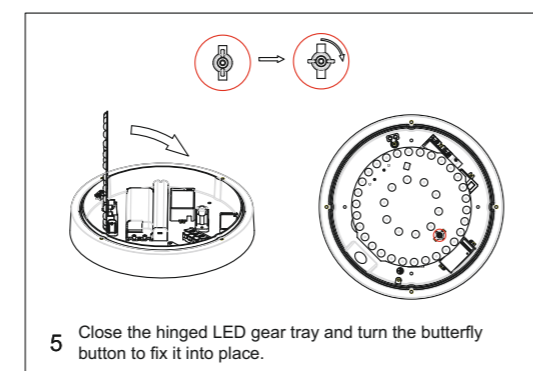
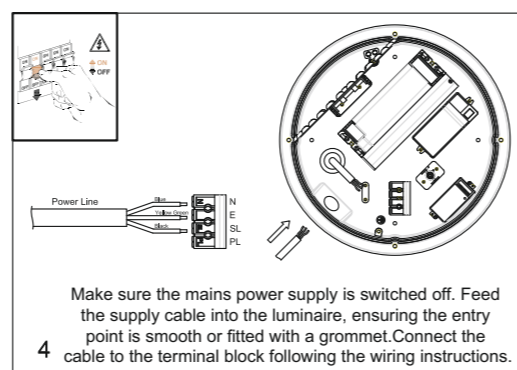
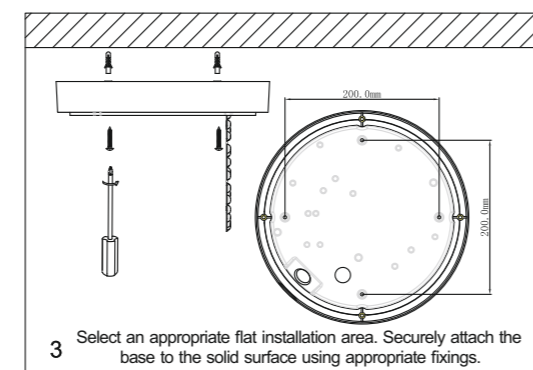
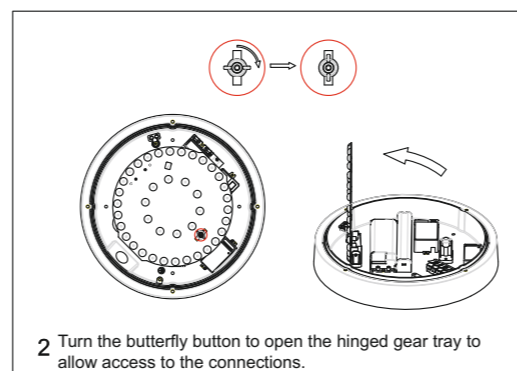
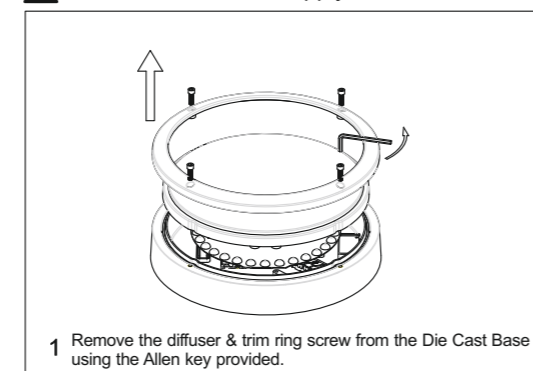

Emergency Pack (LTEM) and Microwave Sensor (LTMS) Installation Instructions

Switch off the mains supply before installation.

Emergency Pack (LTEM) Installation:

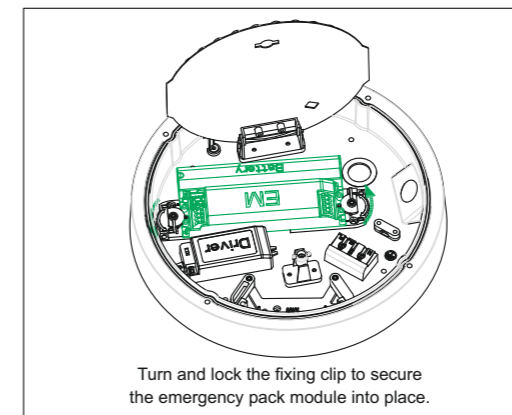
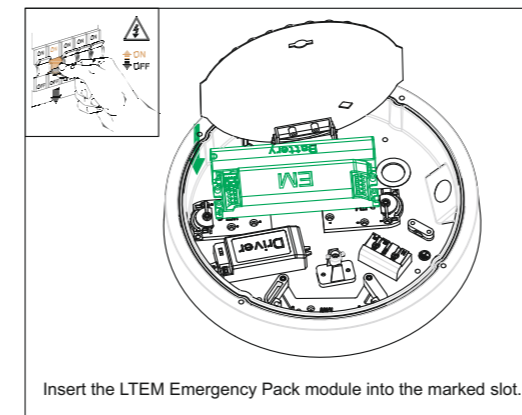

Microwave Sensor (LTMS) Installation:

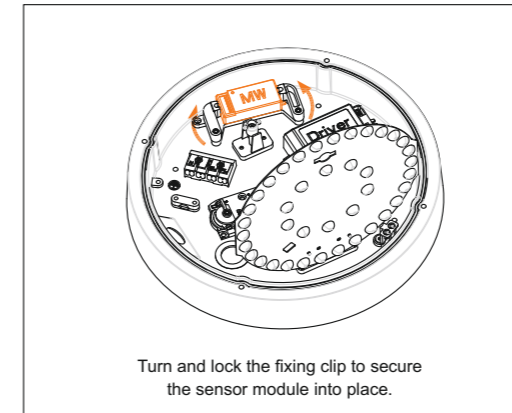
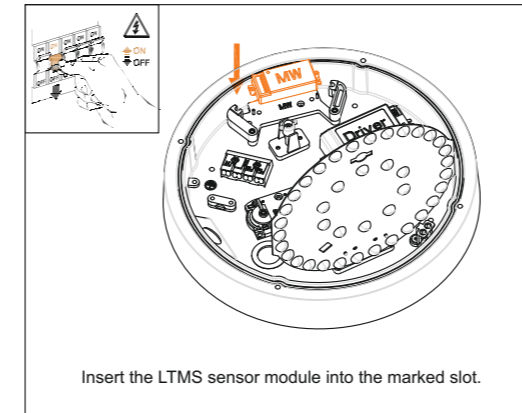

Emergency Pack (LTEM) and Microwave Sensor (LTMS) Installation:

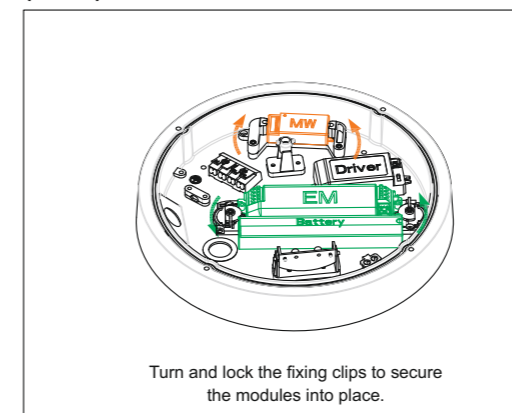
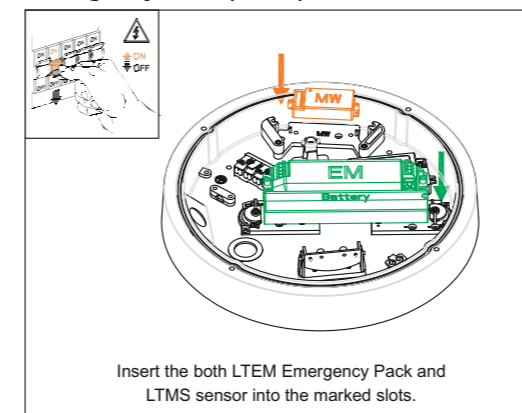

LTEM & LTMS PLUG & PLAY INSTALLATION INSTRUCTIONS

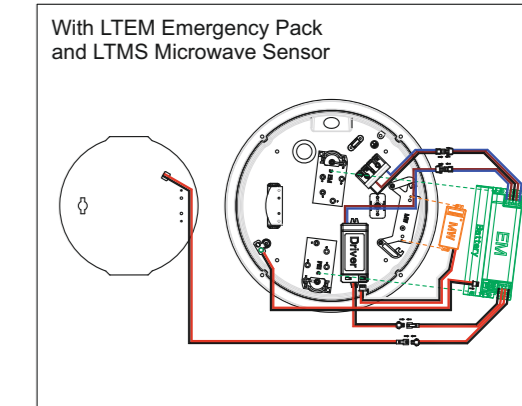
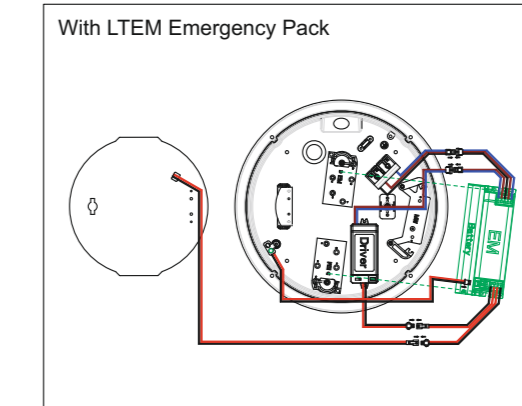
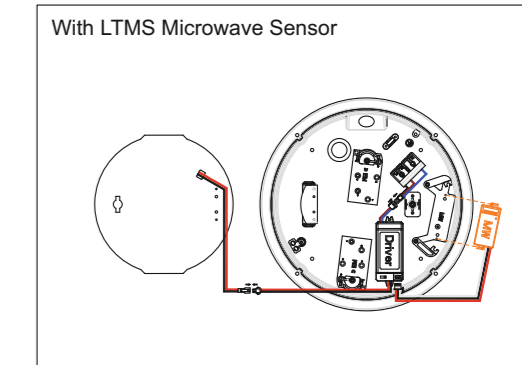
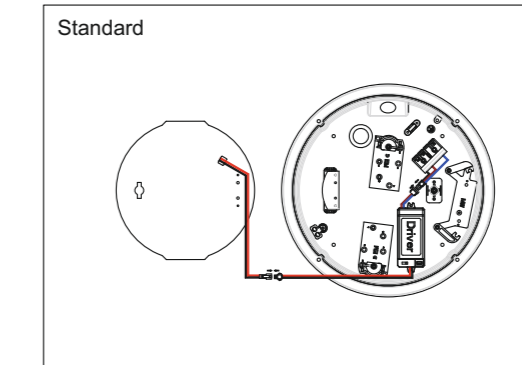

Changing trims Installation Instructions:

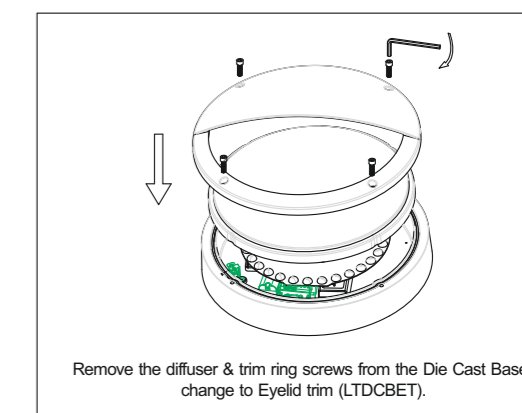
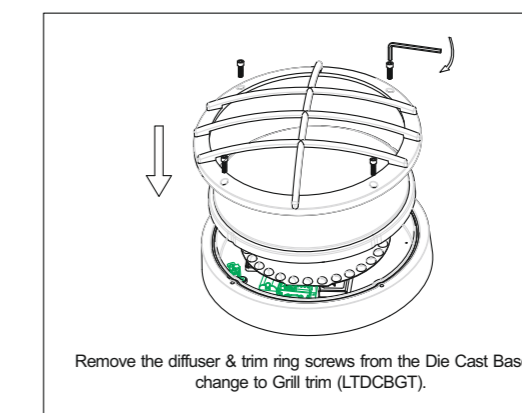

For further information visit www.tlc-direct.co.uk

