



**STORED & SECURED.**



# PRODUCT GUIDE

2019 | Vehicle & On-Site Range



# STORED & SECURED.

Vault Vault is for storage and security, in vehicles and on site. We're the market leader. Recognised as the leading brand for mobile security containers - we're all about tool theft prevention.



## ON THE SIDE OF TRADESPEOPLE.

Tool theft is brutal when it happens. It's rife, it's on the rise and it's a massive issue facing tradespeople. The response to tool theft is Van Vault.

We make the working day of tradespeople better, giving them the means to protect their tools and the ability to work.

Hard-working people have the right to know their tools are secure. That's why we've done the research and rigorous testing, so we know our product works.

## CONTENTS

### VEHICLE STORAGE

Mobi	8
Van Vault 2	10
Outback	12
Tipper	14
XL	16
Stacker XL	18
Slider	20
Slim Slider	22
Roof Tube	24

### ON-SITE STORAGE

4-Site / 4-Store	26
Chem Safe / Chem Store	28
Fire Safe / Fire Store	30
Fuel 'N' Tool	32
Gas Cage	32
Battery Bank	32

### ACCESSORIES

Cobra Chains	34
Straps	34
Locks	35
Castor Sets	35
Dividers	35
Docking Station	35
Spares	35



Advice on product selection and installation instructions are also available on our website [vanvault.co.uk](http://vanvault.co.uk)

# VEHICLE STORAGE

Pages 5 - 24

## WHY CHOOSE VAN VAULT?

### THE NO.1 BRAND

Van Vault is the UK's No.1 vehicle secure storage brand. We lead in awareness, consideration, preference and brand image\*. You'll find Van Vault in more vans than any other secure storage brand.

### CERTIFIED PRODUCT

Van Vault is the first in-vehicle secure storage product tested and certified by Sold Secure and Secured by Design - the UK's official police preferred specification.

### BUILT FOR VEHICLES

Our range of vehicle products are built to be mobile for any vehicle. We've tried and tested them so they stand up to rigours of movement.

### UNIQUE PRODUCTS

Best known for our range of vehicle boxes, our drawer systems are unique to Van Vault.

### EXPERIENCE, KNOWLEDGE & INNOVATION

The very first Van Vault, the Original, was invented and built by us. Our 21 years of knowledge and experience means you get a quality product that works. Innovation is key as we react to what customers' really want.

### DELIVERY

We offer free next working day delivery to anywhere in mainland UK for orders over £100.

\*Independent Van Vault research, 2018.



# MAXIMUM SECURITY.

Reinforced for the toughest build ever, the common areas thieves attack have been strengthened with added security features:

## TESTED & CERTIFIED

We aren't the only ones calling the Van Vault vehicle range the ultimate tool security and storage product. Tested by the best, you can't afford to be without your tools. Therefore, you can't afford to be without the first vehicle secure storage products on the market with these two certifications:



### SOLD SECURE

An independent test house for security products, owned by the Master Locksmith Association. They test products using a variety of tools and techniques to push them beyond what they're expected to handle.



### SECURED BY DESIGN

The flagship UK police initiative, Secured by Design promotes products which prevent crime, usually by resistance to attack. The only form of police accreditation for UK products, Van Vault is a proud member of Secured by Design.



## REINFORCED VAULT & LID

- A tougher build with increased steel thickness.
- The full length lid brace grips the front of the box so won't budge when attacked.
- The cross bar reinforcement increases the rigidity of the lid.
- The flush front lid is impervious to car jacks and crowbars.



## VAULTLOCK™ LOCKING SYSTEM

Unique to Van Vault, the Vaultlock™ locking system provides advanced protection against drilling, cutting and picking.



## MORE FLEXIBILITY, MORE FUNCTIONALITY.

- Wide-mouth drop front gives greater access and visibility of the contents inside.
- Gas strut is positioned through the body of the box for easier access and one-handed opening.
- Recessed lock protects keys from damage when left in the lock.
- Reinforced steel mounting points now come with an anti-theft fixing kit.



**VEHICLE SECURE STORAGE BOX**



**PRODUCT SPECIFICATION**

Part No:	S10850
Weight:	32.25Kg
External dimensions:	780 (L) x 415 (D) x 370 (H)
External with lid open:	780 (L) x 415 (D) x 680 (H)
Internal dimensions:	690 (L) x 325 (D) x 360 (H)

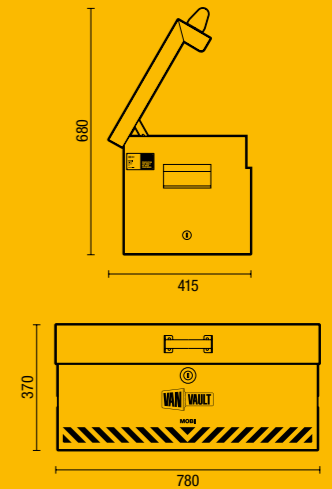

**MOBI  
DROP & DOCK.**

One simple job always leads to another, but the Mobi keeps you mobile and your tools secure.

Move between jobs using the lockable docking station and make short work of every task, every time, using the right tool - no more back and forth.

Highly secure - including the reinforced lid and locking system - means you can get on with the job.

The Mobi is certified by Secured by Design, the UK's Police preferred specification.



**FEATURES & BENEFITS**

- Built with a 2mm steel construction with fully phosphated anti-corrosion protection.
- Fitted with two highly effective 70mm anti-pick, anti-drill and anti-rust stainless steel disc locks.
- The Vaultlock™ is positioned deep within the body of the box, protected by a hardened steel plate.
- Supplied with 3 keys (per lock).
- The reinforced lid protects against attacks with crowbars or car jacks.
- Bolt-on lid handle designed to shear off if attacked.
- Wide mouth drop front for greater access and visibility of contents inside.
- 4 reinforced fixing points for easy installation to the vehicle floor - instructions & bolts supplied.
- Secures to Docking Station, included.

**COMPATIBLE WITH...**

**Mobi Docking Station**  
Extra Docking Stations are available for mounting in multiple locations.  
**Part No:** S10310



**STORAGE**

A helpful guide to what tools the Mobi can hold.

Power Tools	✓	Piping	✗
Large Power Tools	✗	Small Transformers	✗
Hand Tools	✓	Large Transformers	✗
Large Hand Tools	✗	Power Tool Accessories	✓





PRODUCT SPECIFICATION

Part No:	S10810
Weight:	48Kg
External dimensions:	935 (L) x 590 (D) x 494 (H)
External with lid open:	935 (L) x 590 (D) x 920 (H)
Internal dimensions:	790 (L) x 430 (D) x 478 (H)

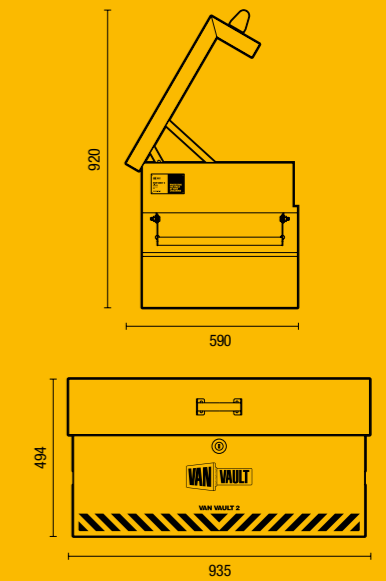

# VAN VAULT 2

## THE ORIGINAL. THE ULTIMATE.

Tool theft is rife and on the rise. Meet that challenge with the toughest, most secure version of the original Van Vault 2.

All your valuable kit is stored and secured behind a heavy duty steel body with a reinforced lid and advanced protection locking system.

Van Vault 2 is the first secure storage product for vehicles to have been independently tested and certified by Secured by Design, the UK's Police preferred specification.

If you can't afford to be without your tools, you can't afford to be without the Van Vault 2.



### FEATURES & BENEFITS

- Built with a 3mm steel construction with fully phosphated anti-corrosion protection.
- Strong gas strut support arm ensures a soft open and close lid action. Positioned through the side of the box to optimise storage space.
- Fitted with a highly effective 70mm anti-pick, anti-drill and anti-rust stainless steel disc lock.
- The Vaultlock™ is positioned deep within the body of the box, protected by a hardened steel plate.
- Supplied with 3 keys.
- The reinforced lid protects against attacks with crowbars or car jacks.
- Reinforcing plates, lid front brace and cross bracing all protect the lid from being prised open.
- Drop down recessed handles with rubber pads provide maximum comfort when lifting
- Bolt-on lid handle designed to shear off if attacked.
- Wide mouth drop front for greater access and visibility of contents inside.
- 4 reinforced fixing points for easy installation to the vehicle floor - instructions & bolts supplied.
- Pre-drilled fitting points for optional castors.

### COMPATIBLE WITH...

**Stacker XL**

For extra storage, without taking up more floor space, combine the Stacker XL with a Van Vault 2.

Part No: S10890



### STORAGE

A helpful guide to what can fit in a Van Vault 2.

Power Tools	✓	Piping	✗
Large Power Tools	✗	Small Transformers	✓
Hand Tools	✓	Large Transformers	✗
Large Hand Tools	✗	Power Tool Accessories	✓





**PRODUCT SPECIFICATION**

Part No:	S10820
Weight:	60Kg
External dimensions:	1335 (L) x 558 (D) x 490 (H)
External with lid open:	1335 (L) x 558 (D) x 920 (H)
Internal dimensions:	1244 (L) x 430 (D) x 484 (H)

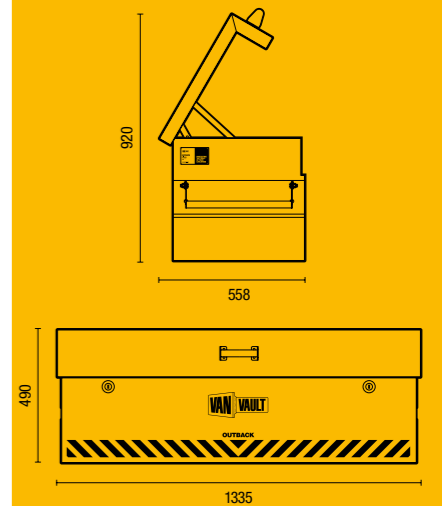

# OUTBACK

## GOT YOUR BACK.

Your tools go where you go in the Outback, shielded from the elements and from theft.

Bolted down and reinforced, your kit is kept secure against the bulkhead of the vehicle, and to hand when you need it most.

Out and about, or left stationary, your tools are always protected.

The Outback is accredited by the UK's official police initiative - Secured by Design.



### FEATURES & BENEFITS

- Built with a 3mm steel construction with fully phosphated anti-corrosion protection.
- Strong gas strut support arms ensures a soft open and close lid action. Positioned through the side of the box to optimise storage space.
- Fitted with 2 highly effective 70mm anti-pick, anti-drill and anti-rust stainless steel disc locks.
- The Vaultlock™ is positioned deep within the body of the box, protected by hardened steel plates.
- Supplied with 3 keys (per lock).
- The reinforced lid protects against attacks with crowbars or car jacks.
- Reinforcing plates, lid front brace and cross bracing all protect the lid from being prised open.
- Drop down recessed handles with rubber pads provide maximum comfort when lifting.
- Bolt-on lid handle designed to shear off if attacked.
- Wide mouth drop front for greater access and visibility of contents inside.
- 4 reinforced fixing points for easy installation to the vehicle floor - instructions & bolts supplied.
- Pre-drilled fitting points for optional castors.

### STORAGE

A helpful guide to what can fit in an Outback.

Power Tools	✓
Large Power Tools	✓
Hand Tools	✓
Large Hand Tools	✓
Piping	✗
Small Transformers	✓
Large Transformers	✗
Power Tool Accessories	✓





### PRODUCT SPECIFICATION

Part No:	S10830	External dimensions:	1815 (L) x 560 (D) x 490 (H)
Weight:	80Kg	External with lid open:	1815 (L) x 560 (D) x 920 (H)
		Internal dimensions:	1720 (L) x 435 (D) x 420 (H)

# TIPPER

## BIG JOBS. BIG TOOLS.

Tried and tested, the Tipper fits against the bulkhead of any open backed vehicle, keeping all your important kit stored and protected from the elements. The extra width makes it right for the equipment you can't be without.

It benefits from all the latest security features to keep thieves out, including a strong steel build, reinforced lid and advanced protection locking system.

The Tipper is certified by Secured by Design, the UK's Police preferred specification.



### FEATURES & BENEFITS

- Built with a 3mm steel construction with fully phosphated anti-corrosion protection.
- Strong gas strut support arms ensures a soft open and close lid action. Positioned through the side of the box to optimise storage space.
- Fitted with 2 highly effective 70mm anti-pick, anti-drill and anti-rust stainless steel disc locks.
- The Vaultlock™ is positioned deep within the body of the box, protected by hardened steel plates.
- Supplied with 3 keys (per lock).
- The reinforced lid protects against attacks with crowbars or car jacks.
- Reinforcing plates, lid front brace and cross bracing all protect the lid from being prised open.
- Sloping lid to channel water away.
- Drop down recessed handles with rubber pads provide maximum comfort when lifting.
- Bolt-on security handle designed to shear off if attacked.
- Wide mouth drop front for greater access and visibility of contents inside.
- 4 reinforced fixing points for easy installation to the vehicle floor - instructions & bolts supplied.
- Pre-drilled fitting points for optional castors.

### STORAGE

A helpful guide to what can fit in a Tipper.

- Power Tools ✓
- Large Power Tools ✓
- Hand Tools ✓
- Large Hand Tools ✓
- Piping ✓
- Small Transformers ✓
- Large Transformers ✓
- Power Tool Accessories ✓







**PRODUCT SPECIFICATION**

Part No:	S10840
Weight:	82Kg
External dimensions:	1190 (L) x 645 (D) x 635 (H)
External with lid open:	1190 (L) x 645 (D) x 1155 (H)
Internal dimensions:	1150 (L) x 580 (D) x 595 (H)

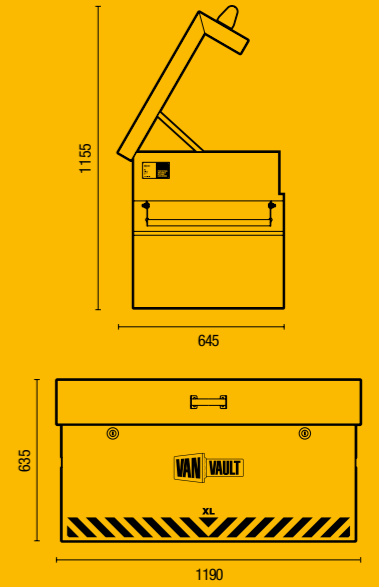

# XL

## STORE MORE.

Bigger and bolder, keep more of your equipment secure with the Van Vault XL. When your work means you need bigger tools, you need a bigger vehicle security box.

Suited to large vehicles, you can take more with you without the worry of theft. That means everything is on hand and every job can be completed.

The XL is accredited by the UK's official police initiative - Secured by Design.



### FEATURES & BENEFITS

- Built with a 3mm steel construction with fully phosphated anti-corrosion protection.
- Strong gas strut support arm ensures a soft open and close lid action. Positioned through the side of the box to optimise storage space.
- Fitted with 2 highly effective 70mm anti-pick, anti-drill and anti-rust stainless steel disc locks.
- The Vaultlock™ is positioned deep within the body of the box, protected by hardened steel plates.
- Supplied with 3 keys (per lock).
- The reinforced lid protects against attacks with crowbars or car jacks.
- Reinforcing plates, lid front brace and cross bracing all protect the lid from being prised open.
- Drop down recessed handles with rubber pads provide maximum comfort when lifting.
- Bolt-on security handle designed to shear off if attacked.
- Wide mouth drop front for greater access and visibility of contents inside.
- 4 reinforced fixing points for easy installation to the vehicle floor - instructions & bolts supplied.
- Pre-drilled fitting points for optional castors.

### STORAGE

A helpful guide to what can fit in an XL.

Power Tools	✓
Large Power Tools	✓
Hand Tools	✓
Large Hand Tools	✓
Piping	✗
Small Transformers	✓
Large Transformers	✓
Power Tool Accessories	✓





**PRODUCT SPECIFICATION**

Part No:	S10890	External dimensions:	910 (L) x 485 (D) x 313 (H)
Weight:	39Kg	Internal dimensions:	885 (L) x 390 (D) x 227 (H)

**ALWAYS ON HAND.  
ALWAYS SECURE.**



# STACKER XL

## LOAD IT. LOCK IT.

Customise your vehicle storage to suit. The Stacker XL provides lots of secure drawer space for valuable tools.

Useful on its own, the Stacker XL also expands your other Van Vault storage setup by combining with the Van Vault 2 or another Stacker XL, stack together without taking up any more floor space in your van.

The smooth-action drawer secures your tools but keeps them accessible.

The Stacker XL is certified by Secured by Design, the UK's Police preferred specification.



### FEATURES & BENEFITS

- Built with a solid steel construction with fully phosphated anti-corrosion protection.
- Heavy duty roller bearings combined with full drawer runners provide a smooth drawer action.
- Soft foam insert protects tools from damage.
- Load capacity: 300Kg.
- Fitted with a highly effective 70mm anti-pick, anti-drill and anti-rust stainless steel disc lock.
- The Vaultlock™ is positioned deep within the body of the drawer, protected by a hardened steel plate.

- Supplied with 3 keys.
- Steel grip handles for easy opening.
- Compatible with Van Vault 2 and Stacker XL.
- Pre-drilled fixing points for easy installation to the vehicle floor and to other Van Vault products - instructions & bolts supplied.

### COMPATIBLE WITH...

**Van Vault 2**  
For extra storage, without taking up more floor space, combine the Stacker XL with a Van Vault 2.  
**Part No: S10810**



### STORAGE

A helpful guide to what can fit in a Stacker XL.

Power Tools	✓
Large Power Tools	✗
Hand Tools	✓
Large Hand Tools	✗
Piping	✗
Small Transformers	✗
Large Transformers	✗
Power Tool Accessories	✓



**VEHICLE SECURE DRAWER SYSTEM**



**PRODUCT SPECIFICATION**

Part No:	S10870	External dimensions:	500 (L) x 1200 (D) x 310 (H)
Weight:	52.5Kg	Internal dimensions:	444 (L) x 1115 (D) x 260 (H)

**MAXIMUM SECURITY. MAXIMISED SPACE.**



**SLIDER**

**SAFE TOOLS. QUICK ACCESS.**

Stay organised for every job with the Van Vault Slider.

A flexible alternative to the traditional box product, this high security drawer adds extra depth to your tool storage setup. Constructed to take the weight of other equipment - means you can stack on-top and not lose any valuable van space.

Fix the Slider to the rear or side of your van and your kit is ready to grab whenever you need it.

Robust security features mean thieves leave empty-handed. Load it, lock it and get on with the job at hand.

The Slider is certified by Secured by Design, the UK's Police preferred specification.



**FEATURES & BENEFITS**

- Built with a solid steel body with fully phosphated anti-corrosion protection.
- Heavy duty roller bearings combined with full drawer runners provide a smooth drawer action.
- Reinforced slip resistant top designed to take loads e.g. pallet and materials.
- Load capacity: 300Kg.
- Fitted with a highly effective 70mm anti-pick, anti-drill and anti-rust stainless steel disc lock.

- The Vaultlock™ is positioned deep within the body of the drawer, protected by a hardened steel plate.
- Supplied with 3 keys.
- Pre-drilled fixing points for easy installation to the vehicle floor - instructions & bolts supplied.
- Floor mounts between wheel arches.
- Steel grip handle for easy opening.

**OPTIONAL EXTRAS**

**Dividers**  
Get better organised with a set of 4 steel Slider dividers  
Part No: S10914



**STORAGE**

A helpful guide to what can fit in a Slider.

Power Tools	✓
Large Power Tools	✗
Hand Tools	✓
Large Hand Tools	✗
Piping	✗
Small Transformers	✓
Large Transformers	✗
Power Tool Accessories	✓





PRODUCT SPECIFICATION

Part No:	S10880	External dimensions:	1000 (L) x 1200 (D) x 227 (H)
Weight:	77Kg	Internal dimensions:	950 (L) x 1115 (D) x 175 (H)

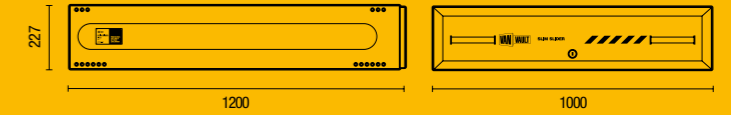

ALWAYS ON HAND. ALWAYS SECURE.



# SLIM SLIDER

## MAKE ROOM.

Maximise the floor space in your vehicle with the Slim Slider.

Get quick access to vital tools on the job while keeping things organised.

Constructed to take the weight of other equipment - means you can stack on-top and not lose any valuable van space.

Along with all the best security features, this low slider keeps tools together and thieves out.

The Slim Slider is certified by Secured by Design, the UK's Police preferred specification.



### FEATURES & BENEFITS

- Built with a solid steel body with fully phosphated anti-corrosion protection.
- Heavy duty roller bearings combined with full drawer runners provide a smooth drawer action.
- Reinforced slip resistant top designed to take loads e.g. pallet.
- Load capacity: 300Kg.
- Fitted with a highly effective 70mm anti-pick, anti-drill and anti-rust stainless steel disc lock.

- The Vaultlock™ is positioned deep within the body of the drawer, protected by a hardened steel plate.
- Supplied with 3 keys.
- Pre-drilled fixing points for easy installation to the vehicle floor - instructions & bolts supplied.
- Floor mounts between wheel arches.
- Steel grip handle for easy opening.

### OPTIONAL EXTRAS

**Dividers**  
Get better organised with a set of 4 steel Slim Slider dividers  
Part No: S10915



### STORAGE

A helpful guide to what can fit in a Slim Slider.

Power Tools	✓
Large Power Tools	✗
Hand Tools	✓
Large Hand Tools	✗
Piping	✗
Small Transformers	✗
Large Transformers	✗
Power Tool Accessories	✓





## ROOF TUBE 100



### THE TOUGH TUBE.

Thieves target valuable materials, so secure your copper piping with the Roof Tube 100.

Maximise the storage space in your van by keeping lengthy piping overhead and ready to use.

Heavy caps keep your piping in place, whether your vehicle is stationary or you have to hit the brakes while driving.

#### PRODUCT SPECIFICATION

Part No:	S10520	External dimensions:	115 (H) x 3152 (L) x 138 (D)
Weight:	8.25Kg	Internal:	90 (H) x 3156 (L) x 126 (D)

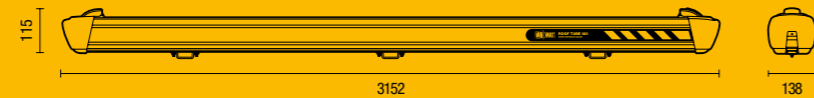

#### FEATURES & BENEFITS

- Lightweight tough 1.5mm thick aluminium.
- Holds 100m of copper in 34 x 3m lengths.
- Injection moulded end cap with steel insert - prevents risk of spillage during heavy braking.
- Dual end loading.
- 2 x 40mm Brass Padlocks supplied (3 keys per padlock).
- Supplied with roof fixing mounts.

#### STORAGE

A helpful guide to what can fit in a Roof Tube 100

- 34x** 15mm tubes
- 24x** 22mm tubes
- 15x** 28mm tubes

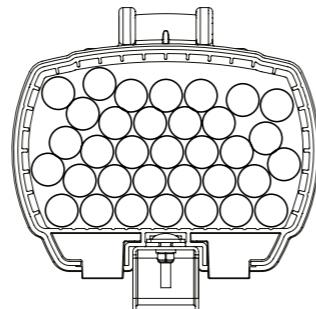

# ON-SITE STORAGE

Pages 25 - 33

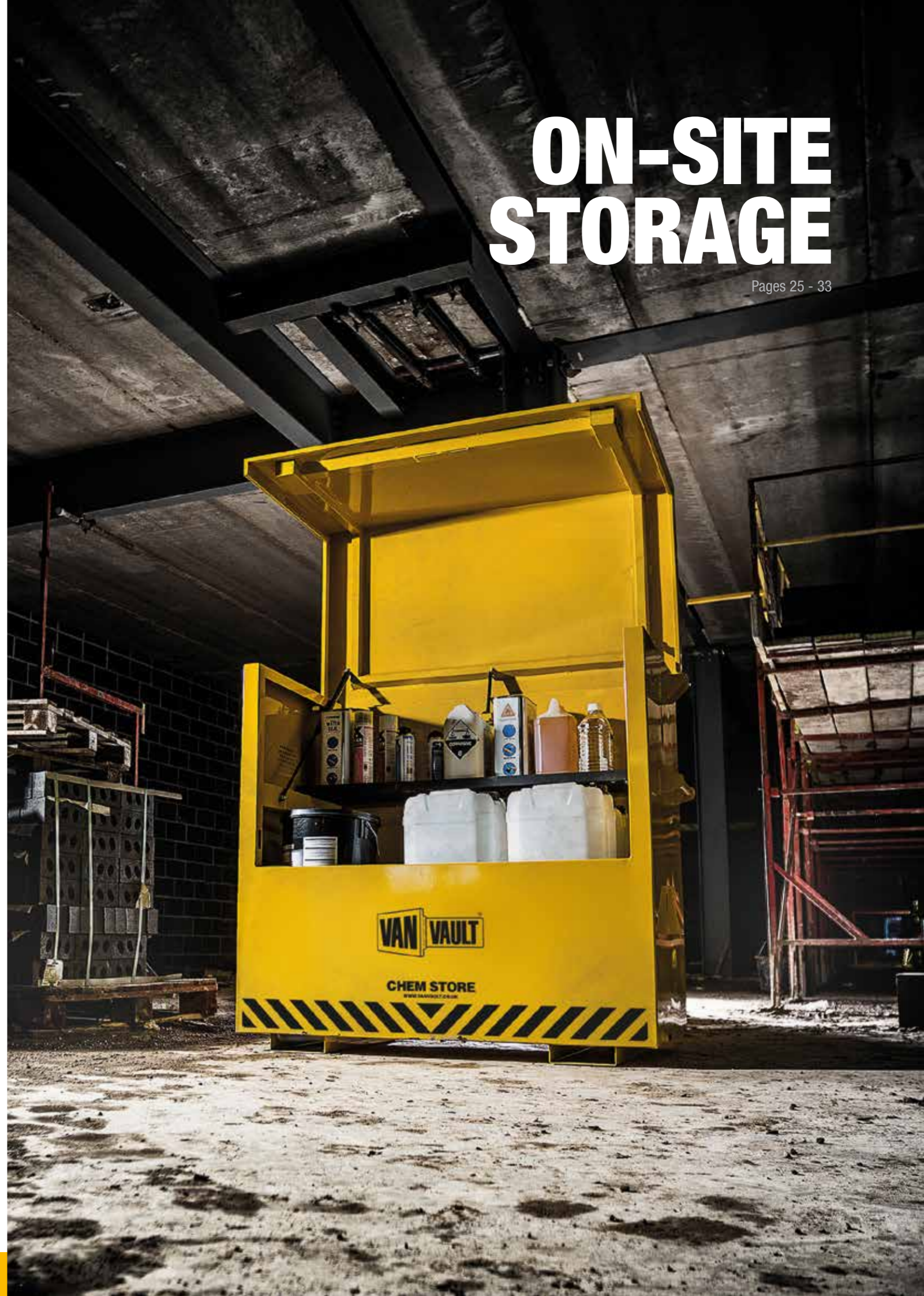



**PRODUCT SPECIFICATION**

**4-SITE**

Part No:	S10270
Weight:	60Kg
External dimensions:	1190 (L) x 645 (D) x 750 (H)
External with lid open:	1190 (L) x 645 (D) x 1200 (H)
Internal dimensions:	1150 (L) x 580 (D) x 595 (H)

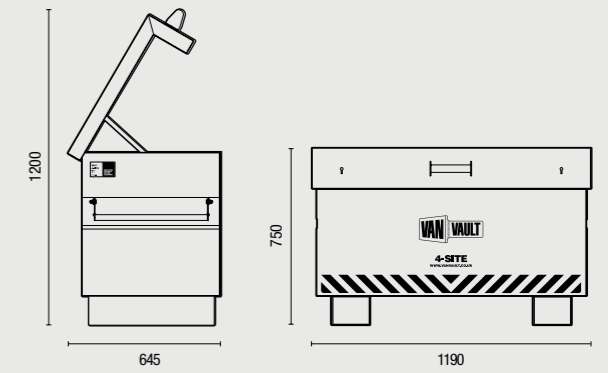

**4-SITE & 4-STORE  
BUILT TOUGH.**

Stored and secured. Day and night. Van Vault 4-Site and 4-Store containers mean you can leave valuable tools and equipment on-site, at your workplace without issue.

Heavy-duty body, powder-coating and a 2-point locking system to keep thieves out, protect against weathering and keep your tools where you need them.



**FEATURES & BENEFITS**

- 2.5mm sheet steel construction with fully phosphated anti-corrosion protection.
- 2 x 5-lever British Standard Locks.
- Supplied with two keys.
- Integrated single pin hinge.
- Gas strut support arms.
- Solid lock 'lid stay' system.
- Fitted with shelf brackets.
- Drop down handles (4-Site only).
- Crane hook anchor brackets (4-Store only).
- New enlarged fork skids, allowing easy loading access for pallet trucks and fork lifts.



**4-STORE**

Part No:	S10280
Weight:	173Kg
External dimensions:	1282 (L) x 735 (D) x 1280 (H)
External with lid open:	1282 (L) x 735 (D) x 1950 (H)
Internal dimensions:	1121 (L) x 665 (D) x 1111 (H)

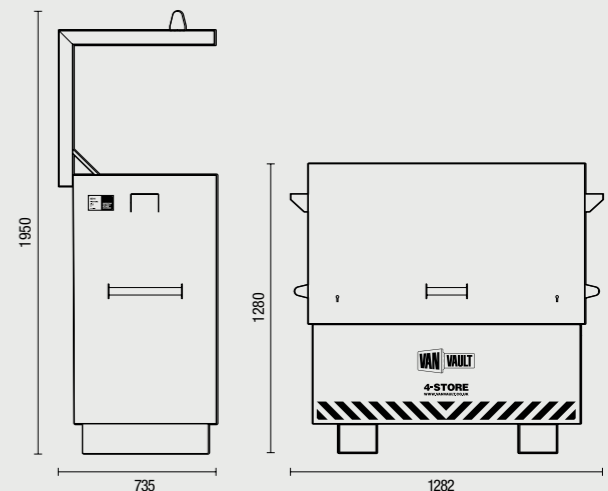



**PRODUCT SPECIFICATION**

**CHEM SAFE**

Part No:	<b>S10022</b>
Weight:	97Kg
External dimensions:	1190 (L) x 645 (D) x 750 (H)
External with lid open:	1190 (L) x 645 (D) x 1200 (H)
Internal dimensions:	1150 (L) x 580 (D) x 575 (H)

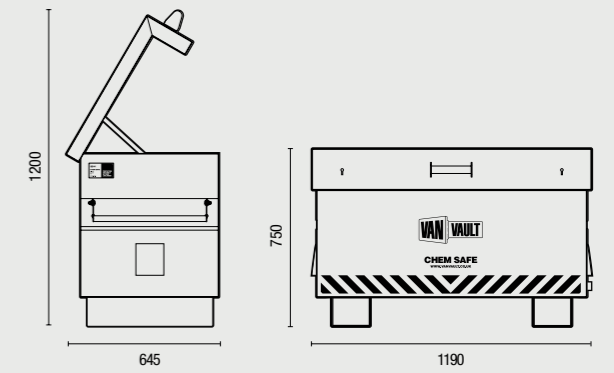

# CHEM SAFE & CHEM STORE

## HAZARD CONTROL.

Accidental spillages and sudden overflows are contained with the Chem Safe and Chem Store units, while valuable hazardous chemicals are kept out of the wrong hands.

Built with drip trays, brass drainage taps and a large welded bund, these storage containers keep your site safe and your assets secure, on-site.



**FEATURES & BENEFITS**

- Manufactured for storage of hazardous chemicals.
- Fully ventilated.
- Fitted with brass overspill tap.
- Integrated single pin hinge.
- Elevation tray included for spillages.
- Manufactured from 2.5mm sheet steel with fully phosphated and powder coated for a durable finish.
- Internal shelf (Chem Store only).
- 2 x 5-lever British Standard Locks..
- Supplied with two keys.
- Drop down handles (Chem Safe only).
- Crane hook anchor brackets (Chem Store only).
- New enlarged fork skids, allowing easy loading access for pallet trucks and fork lifts.



**CHEM STORE**

Part No:	<b>S10069</b>
Weight:	182Kg
External dimensions:	1282 (L) x 735 (D) x 1280 (H)
External with lid open:	1282 (L) x 735 (D) x 1950 (H)
Internal dimensions:	1245 (L) x 665 (D) x 1111 (H)

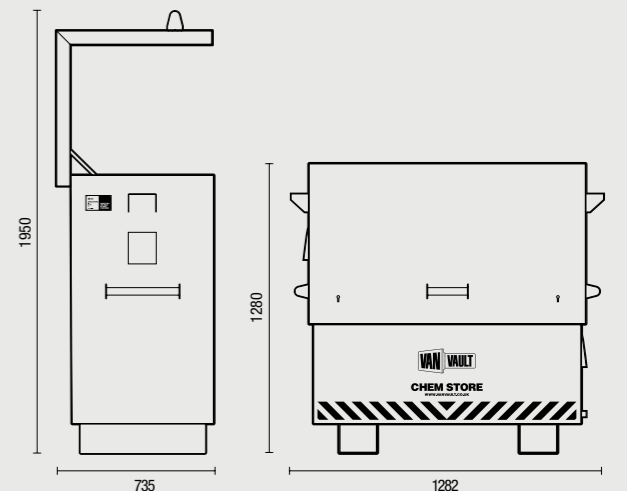



**PRODUCT SPECIFICATION**

**FIRE SAFE**

Part No:	S10020
Weight:	97Kg
External dimensions:	1190 (L) x 645 (D) x 750 (H)
External with lid open:	1190 (L) x 645 (D) x 1200 (H)
Internal dimensions:	1150 (L) x 585 (D) x 595 (H)

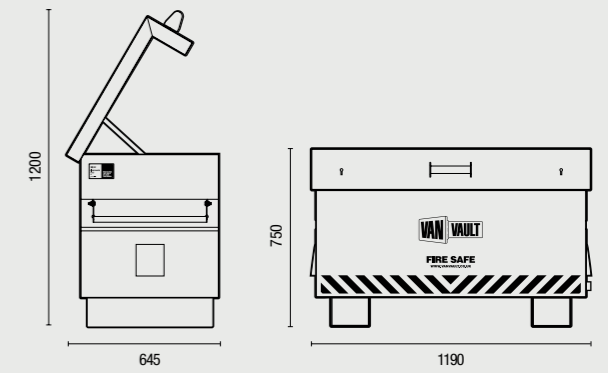

**FIRE SAFE & FIRE STORE**  
**CLOSE IT. CONTAIN IT.**

Key to keeping your site safe, the Fire Safe and Fire Store are designed to organise your flammable liquids and restrict the spread of fires.

Flashback arrestors and a purpose-built body mean fumes escape but sparks and flames cannot get in, giving you up to 30 minutes of resistance to fire. Drip trays and brass taps help you safely contain and drain spills wherever you keep the unit.



**FEATURES & BENEFITS**

- Manufactured for storage of flammable liquids.
- Fully ventilated with gauze flame arrestors.
- Fitted with brass overspill tap.
- Elevation tray included.
- Manufactured from 2.5mm sheet steel.
- Fully phosphated and powder coated for a durable finish.
- Internal shelf (Fire Store only).
- 2 x 5-lever British Standard Locks.
- Supplied with two keys.
- Drop down handles (Fire Safe only).
- Crane hook anchor brackets (Fire Store only).
- New enlarged fork skids, allowing easy loading access for pallet trucks and fork lifts.



**FIRE STORE**

Part No:	S10071
Weight:	182Kg
External dimensions:	1282 (L) x 735 (D) x 1280 (H)
External with lid open:	1282 (L) x 735 (D) x 1950 (H)
Internal dimensions:	1245 (L) x 665 (D) x 1111 (H)

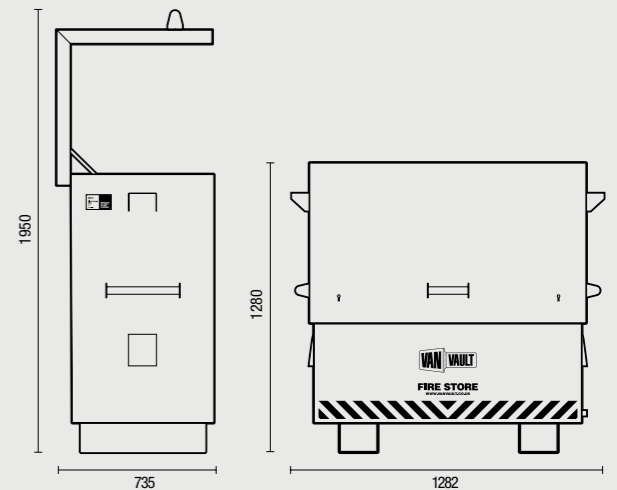



**ON-SITE SECURE STORAGE**

**FUEL 'N' TOOL**

IN ONE PLACE.

**Part No:** S10107  
**External Size:** 645 (L) x 750 (D) x 1190 (H)  
**External with lid open:** 645 (L) x 750 (D) x 1200 (H)  
**Internal Size:** 575 per section (L) x 580 (D) x 595 (H)  
**Weight:** 173Kg



- Two compartments to separate tools and fuel.
- Fitted with brass overspill tap
- 2 x 5-lever BS Locks.
- Supplied with two keys.
- Integrated single pin hinge.
- Heavy gauge 2mm sheet steel construction.
- Fully ventilated with flame arrestors
- New enlarged fork skids, allowing easy loading access for pallet trucks and fork lifts.

**GAS CAGE**

FOLD. MOVE. SECURE.

**Part No:** S10360  
**Dimensions:** 1700 (L) x 880 (D) x 1735 (H)  
**Weight:** 130Kg



- Manufactured from mild steel sections between 3 & 5mm thick.
- Covered with 2" x 2" 10g mild steel, copper coated weld mesh.
- Iron phosphated pre-treatment and powder coated.
- Comes with signs.
- Weights & Dimensions:
  - Body 62.6Kg
  - Lid 14Kg
  - 2x doors 10.1Kg & 12.5Kg
  - 2x internal shelves (735 x 750mm) 7.5Kg each
  - 1x internal shelf (1500 x 700mm) 14Kg

**BATTERY BANK**

CHARGED AND SECURED.

**Part No:** E92000  
**External Dimensions:** 455 (L) x 275 (D) x 11877 (H)  
**Charging Locker:** 200 (L) x 280 (D) x 270 (H)  
**Management Locker:** 420 (L) x 280 (D) x 270 (H)  
**Weight:** 63Kg

10 individually protected lockers and one management locker mean the end of trip hazards on your site, as well as securing valuable batteries and power packs under lock and key while charging.

Electrically safe, certified and fully earthed, secure your site and your tools with this robust battery bank.

- 10 secure lockers each, individually protected with twin 13A RCD sockets.
- Electrically safe and certified, fully earthed and protected by RCDs and an MCB with site specified H07 rubber cable.
- Coin return locking.
- Supplied with 2 keys per lock.
- Master MCB unit to protect all the lockers from site power surges.
- Site specified 3M lead H07 rubber cable with a 16A 240V plug.
- Solid steel construction and fully powder coated to provide excellent anti-corrosive properties.
- Made in the UK.



**Coin Return Locks**  
Ensures key's are returned to the lockers



**RCD Protection**  
Twin 13a RCD sockets in every locker



**Charging Confidence**  
If one Locker trips, remaining will continue to charge



**MCB Protection**  
Protects all lockers from site power surges

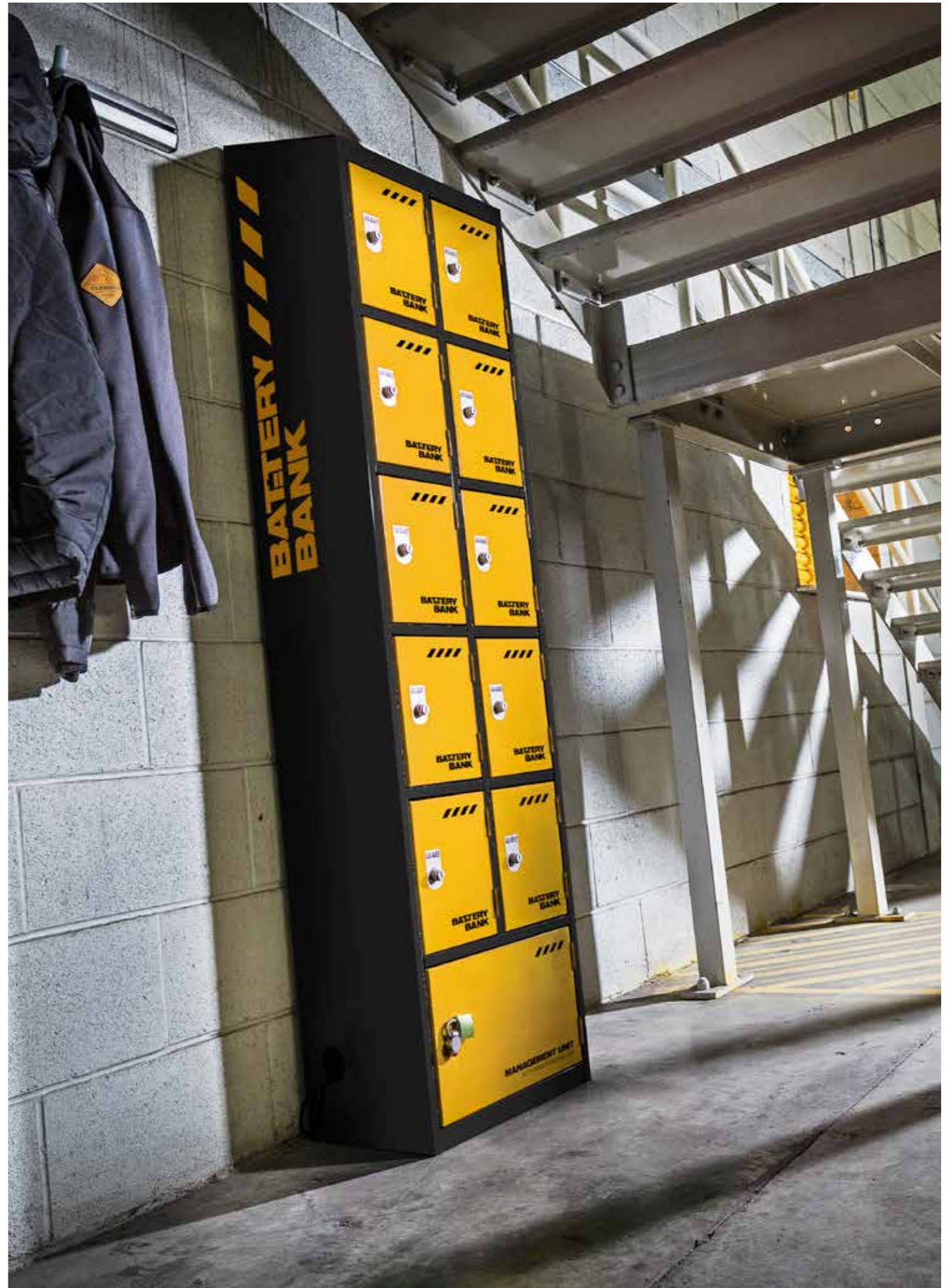

# ACCESSORIES

## CHAINS

Perfect for securing valuable equipment to permanent fixtures.

### COBRA 8

**Part No:** S10120  
**Size:** 1.2mtr of 8mm thick chain.  
**Link size:** 53.5 (L) x 8 (D) x 8 (H)  
**Weight:** 2Kg



- 70mm disc lock.
- Made from hardened steel.
- High density nylon chain cover.
- Toggled nylon carry bag.

### COBRA 11

**Part No:** S10125  
**Size:** 1.5mtr of 11mm thick chain.  
**Link size:** 65 (L) x 11 (D) x 11 (H)  
**Weight:** 3.9Kg



- 'E' slotted lock.
- Made from hardened steel.
- High density nylon chain cover.
- Toggled nylon carry bag.

## STRAPS

Perfect for securing loads from moving in transit.

### RATCHET STRAPS

**5.0M x 25mm Ratchet Strap**  
 Lashing Capacity: 300Kg  
**Part No:** S10673

**3.0M x 25mm Ratchet Strap**  
 Lashing Capacity: 300Kg  
**Part No:** S10677

### ENDLESS STRAPS

**1M x 25mm Endless Strap (Pair)**  
 Lashing Capacity: 160Kg  
**Part No:** S10678

**3.2M x 25mm Endless Strap (Pair)**  
 Lashing Capacity: 160Kg  
**Part No:** S10679

**4.5M x 25mm Endless Strap (Pair)**  
 Lashing Capacity: 160Kg  
**Part No:** S10680

- Made from flexible yet durable polyester webbing.
- Straps secure loads from moving in transit.
- EN12195-2 certified for use on industrial, commercial and domestic vehicles.



## LOCKS

Extra or replacement Van Vault locks.

### 70mm DISC LOCK

**Part No:** Single Pack: S10064 / S10063  
 Twin Pack: S10029 / S10028  
**Weight:** 284g

- For use with Van Vault security containers and as a padlock.
- Supplied with 3 keys per lock.
- Fits Van Vault security boxes.
- Anti-drill plate.
- Hardened steel chrome-plated shackle.
- Pick resistant, three axis (dimple key) tumbler.



### 5-LEVER BRITISH STANDARD LOCKS

**Part No:** S10047  
**Weight:** 350g each

- Compatible with:
  - Van Vault site safes,
  - Van Vault site stores
  - 4-Site
- Two replacement locks .
- Includes 2 identical keys.
- Designed to resist drilling, and lock picking.
- Hardened steel plates.
- British Standard BS3621.



## DIVIDERS

4x strong steel dividers to partition and easily organise the Slider & Slim Slider.

### DIVIDERS FOR SLIDER

**Part No:** Old style: S10330  
 New style with side runners: S10914  
**Weight:** 5.7Kg

- 1mm sheet steel construction.
- Set of 4 Dividers for separating tools and equipment in the Slider.
- Does not come with a Slider.



### DIVIDERS FOR SLIM SLIDER

**Part No:** Old style: S10331  
 New style with side runners: S10915  
**Weight:** 5.7Kg

- 1mm sheet steel construction.
- Set of 4 Dividers for separating tools and equipment in the Slim Slider.
- Does not come with a Slim Slider.



## CASTOR SETS

Get your Van Vaults mobile on-site.

### CASTOR SET

**Part No:** S10099  
**Weight:** 2.25Kg

- Compatible with: Van Vault 2
- Set of 4 heavy duty wheels, 2 with safety brakes.
- Press brake.
- Tough nylon wheels.
- 1.5mm plated steel chassis.



### CASTOR SET

**Part No:** S10085  
**Weight:** 3.7Kg

- Compatible with:
  - Outback, Tipper, XL
  - 4-Site, Chem Safe / Fire Safe
  - Fuel 'N' Tool
- Set of 4 heavy duty wheels, - 2 non-swivel, - 2 swivel with safety brake.
- Press brake.
- Tough nylon wheels.
- 1.5mm plated steel chassis.



## DOCKING STATION

Secure base for remote site installation; for use with the Van Vault Mobi.

**Part No:** S10310  
**Weight:** 4.25Kg

- Optional extra for the Mobi.
- 1.5mm sheet steel construction.
- Fully phosphated anti-corrosion protection.
- Dual locking on docking station.



## SPARES

**BOX FRONT HANDLE**  
**Part No:** S10903  
 VV2, XL, Tipper, Outback & Mobi

**FRONT HANDLE SCREWS**  
**Part No:** S10913

**BOX SIDE HANDLE**  
**Part No:** S10908  
 VV2, Tipper, Outback  
**Part No:** S10909  
 XL

**LID STAY**  
**Part No:** S10910  
 Van Vault 2  
**Part No:** S10911  
 Outback, Tipper, XL, Site, Store, Safe  
**Part No:** S10912  
 Mobi

**GAS STRUTS**  
**Part No:** S10904  
 Van Vault 2 - 350N  
**Part No:** S10905  
 XL - 280N  
**Part No:** S10906  
 Tipper - 300N  
**Part No:** S10907  
 Outback - 250N  
**Part No:** S10060  
 Stores - 600N  
**Part No:** S10068  
 Safes & 4-Site - 440N

**40mm BRASS PADLOCK**  
**Part No:** S10082

**REPLACEMENT FIXING KITS**  
**Part No:** S-VVT-17  
 Roof Tube 100 / 165

**ROOF TUBE 100 END CAP**  
**Part No:** S10507



# VANVAULT.CO.UK

**ADDRESS:**

Birch Park, Park Lodge Road,  
Giltbrook, Nottingham NG16 2AR

**TEL:** +44 (0)115 780 2383

**EMAIL:** [info@vanvault.co.uk](mailto:info@vanvault.co.uk)

Van Vault - designed and distributed by Birchwood Price Tools.  
Birchwood Price Tools is a trading name of Toolstream Limited.  
Van Vault reserves the right to alter or improve specifications without prior notification.